

TODO

TODO® PRODUCTS OVERVIEW

Setting the industry
standard for over
40 years

THE NUMBER 1 CHOICE FOR SAFE LIQUID TRANSFER

TODO® is the market leader in the DRY-BREAK® industry, trusted by clients around the globe. Our products are designed to handle a huge range of oils, gases and hazardous chemicals. For over four decades TODO® valves have been used in the most challenging conditions.



TODO

01

TODO-MATIC®

REDUCED SPILLAGE, INCREASED PROFIT

TODO-MATIC® couplers are extremely reliable, with very few moving parts, and require little operator intervention which reduces the risk of human error. The TODO-MATIC® range's minimal residual loss of product on disconnection and spillage is virtually zero, assuring site safety. Less product leakage also means more product delivered to your customers, resulting in higher profit margins.

TODO® II TANK UNITS

1" TODO-MATIC® DRY-BREAK®DN20
DN32
Ø56 mm
→HOW
IT
WORKS

- Dedicated for small bore applications
- One-handed operation
- High flow rate
- Minimal release on disconnection
- Additional option of selectivity to prevent product cross-contamination

TODO® II TANK UNITS

2" TODO-MATIC® DRY-BREAK®DN32
DN65
Ø70 mm
→HOW
IT
WORKS

- Suitable for various applications
- Available in a range of materials and configurations
- Provides rapid, safe transfer

TODO® II TANK UNITS

2.5" TODO-MATIC® DRY-BREAK®DN65
DN80
Ø105mm
→HOW
IT
WORKS

- Ideal for road tanker and aviation applications
- Suitable for a variety of liquids and vapours
- Strong integral swivel
- Ergonomic design
- Rugged construction

TODO® II TANK UNITS

3" TODO-MATIC® DRY-BREAK®DN80
DN100
Ø119mm
→HOW
IT
WORKS

- Typically used for rail and road loading/discharge
- Tough construction
- Ergonomic design
- High flow rate
- Zero spillage
- The natural choice for NATO refuelling standardisation

TODO® II TANK UNITS

4" TODO-MATIC® DRY-BREAK®DN100
Ø164 mm
→HOW
IT
WORKS

- Rapid connection and disconnection
- Applications include:
 - off-shore ship-to-rig transfer of fuels and drinking water
 - aviation fuel bunkering
 - rail tank loading/discharge
 - chemical transfer

TODO® II TANK UNITS

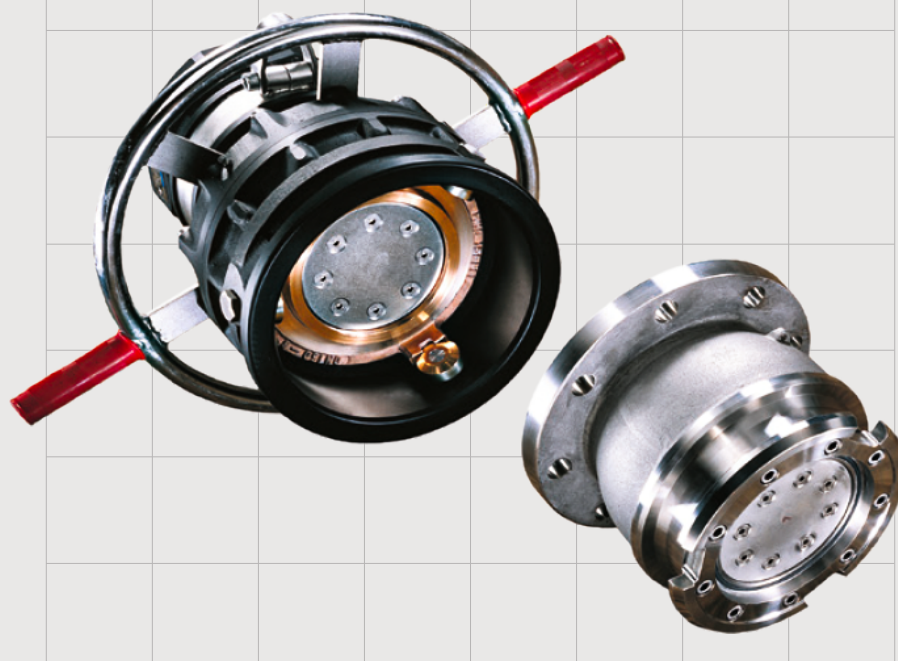
6" TODO-MATIC® DRY-BREAK®DN150
Ø238mm
→HOW
IT
WORKS

- Ideal for ship- or barge-to-shore connection
- Significantly faster transfer than any flange coupling
- Environmental standards compliant
- Provides real turnaround time savings
- Rotating lifting loop as standard

TODO® II TANK UNITS

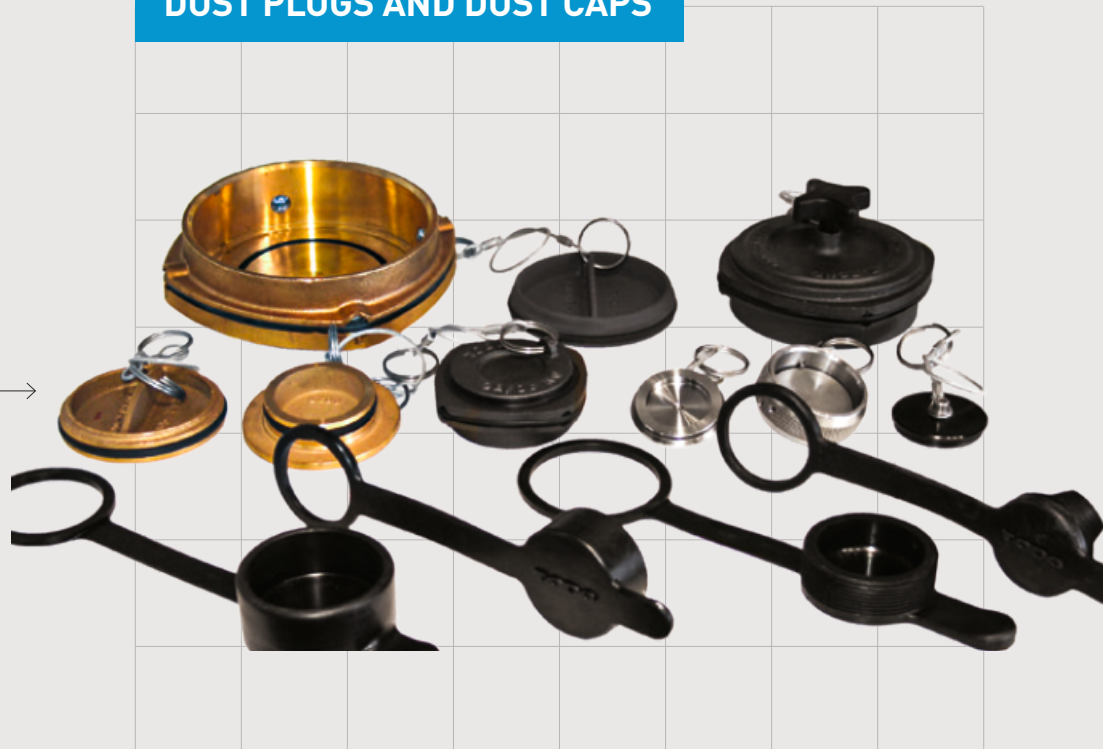
DUST PLUGS AND DUST CAPSSizes:
1"-6"

- Prevent ingress of dirt and water
- Available in:
 - Stainless steel
 - Brass/gunmetal
 - Aluminium
 - Rubber

TODO® II TANK UNITS

02

TODO-GAS

SAFE TRANSFER OF LPG IN BOTH LIQUID AND VAPOUR PHASES

Improve profit margins, environmental credentials and operator safety when transporting liquid petroleum gas. Specifically designed for the safe transfer of LPG, TODO-GAS couplings are composed of materials ideal for the unique properties of LPG and terminal handling properties. TODO-GAS 1" and 2" products have dimensionally different connection geometry to restrict product cross-contamination. Their unrivalled technology also significantly reduces emissions and removes the risk of operator freeze burns.

TODO® II TANK UNITS

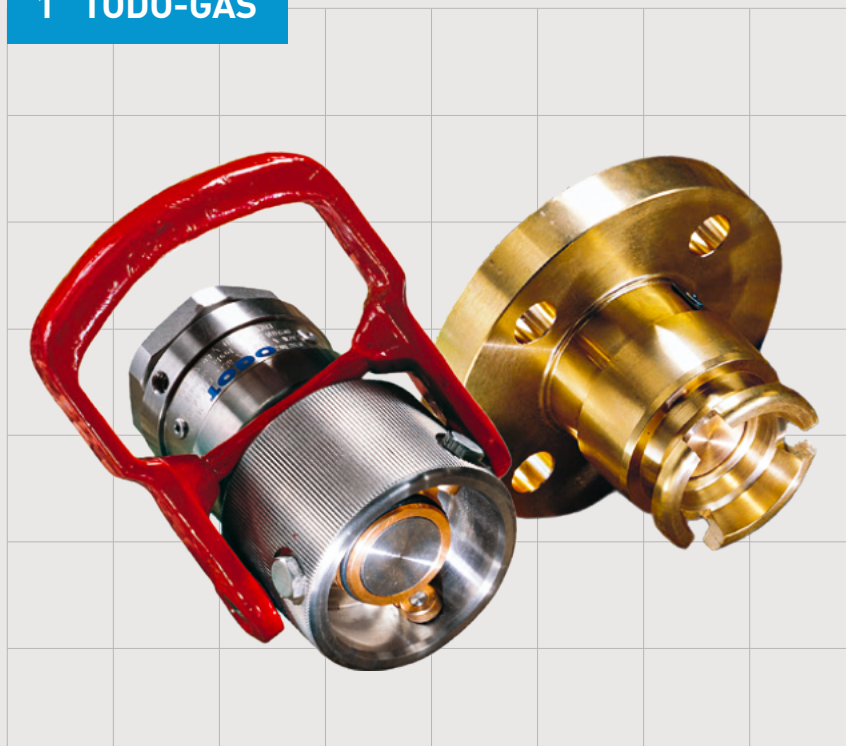
1" TODO-GASDN19
DN32
Ø56 mm
→HOW
IT
WORKS

- Suitable for a range of LPG applications
- Heavy duty autogas vehicle refuelling
- Advanced vapour recovery systems
- Easy to connect and disconnect
- Single-handed operation
- Ultra-low release on disconnect: 0.15cc per disconnection
- Suitable for indoor fuelling
- Handles up to 200 litres/minute (52 USG/MIN)
- Minimal pressure drop

TODO® II TANK UNITS

TODO**2" TODO-GAS**DN40
DN50
Ø71 mm
→HOW
IT
WORKS

- Ideal for bobtails or immediate bulk delivery trucks
- Rugged construction
- Suitable for frequent use
- Can cope with almost any loading equipment configuration
- Ultra low release on disconnect: 0.35cc per disconnection

TODO® II TANK UNITS

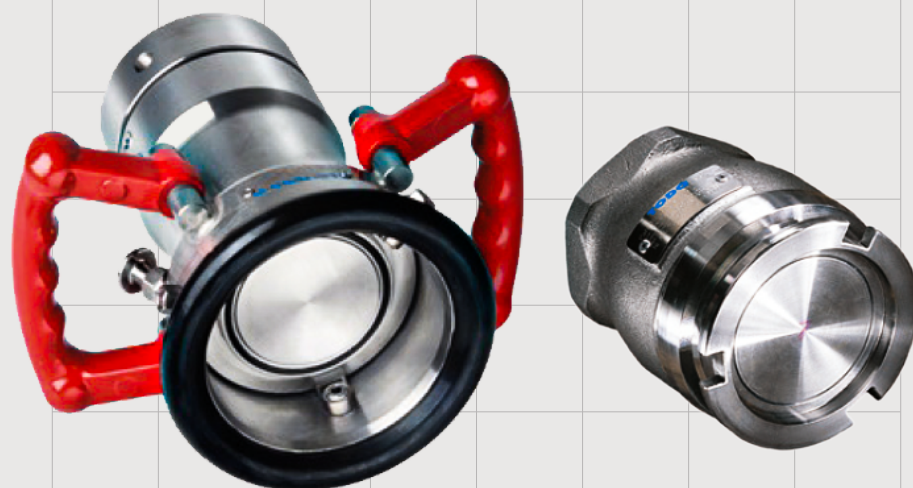
TODO**3" TODO-GAS**DN80
Ø119 mm
→HOW
IT
WORKS

- Unrivalled suitability for larger or high flow rate applications
- Typically used for rail tank loading and discharge
- Handles flows of up to 2,500 litres/minute (658 USG/MIN)
- Two-handle operation
- Robust integral swivel
- Designed to withstand regular use at terminal

TODO® II TANK UNITS

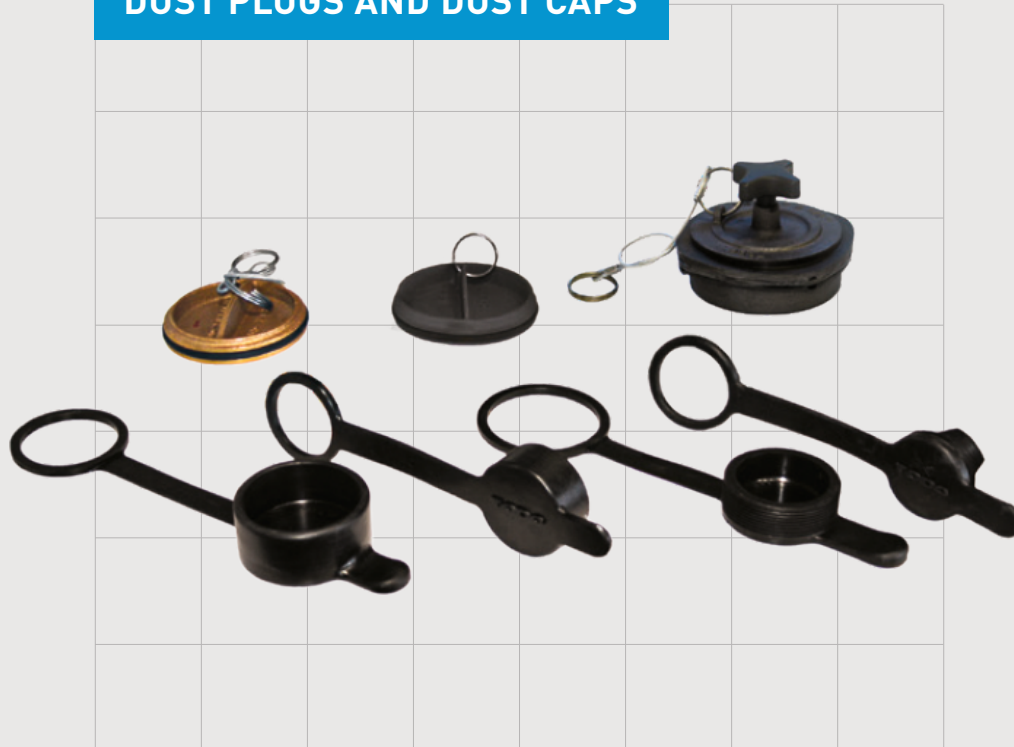
DUST PLUGS AND DUST CAPS

- Prevent ingress of dirt or water
- Materials:
 - 1" and 2" sizes: rubber
 - 3" size: stainless steel, brass/gunmetal and aluminium

TODO® II TANK UNITS



PRESSURE RELIEF VALVE FOR TANK UNIT

- Highly recommended in applications where back-pressure build-up is common. Enables a small amount of pressure to be released in the hose unit to ease coupling motion



PARKING DEVICE

- Provides a position for safe storage of hose units when not in use



LONG DOUBLE HANDLE 2"

- Enables easier coupling motion, especially in applications where space is restricted at the connection point

TODO® II TANK UNITS

03

NGX SERIES

REDUCED SPILLAGE WHEN LOADING OR UNLOADING HAZARDOUS LIQUIDS

The NGX series focuses on preventing damage to the loading system while ensuring minimal product loss. The range combines flow optimisation with the latest innovations to bring you an industry-leading range of Safety Break-Aways. In the event of a drive/pull away incident, break pins are subjected to breaking force and eventually shear, causing the two halves of the Break-Away to separate. The two halves then rapidly close off, preventing liquid/gas from escaping the broken line.

TODO® II TANK UNITS

TODO**2", 3", 4" TODO® BREAK-AWAY**DN50
DN80
DN100
→HOW
IT
WORKS

- Extremely quick closing time
- Minimum loss of product
- Suitable for a wide range of applications

TODO® II TANK UNITS

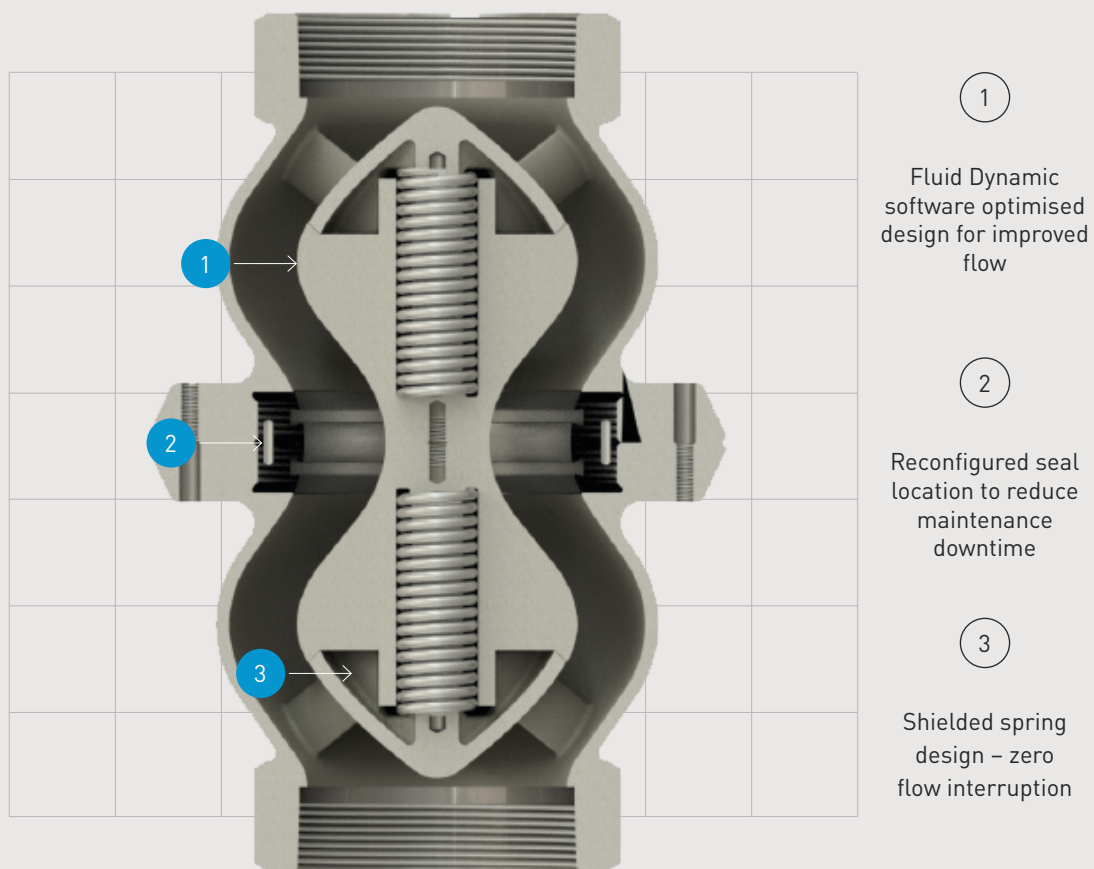
DN50
DN80
DN100
→HOW
IT
WORKS

- Faster loading/unloading due to optimised flow rates
- Simple to retrofit onto loading arms
- Easier to handle when loading/unloading
- Reduced maintenance due to internal redesign and new seal placement
- Easy to reset on-site, saving time and money

TODO® II TANK UNITS

04

MARINE BREAK-AWAY

ELIMINATING SPILLAGE DUE TO SHIP AND/OR BARGE MOVEMENT

The TODO® Marine Break-Away Coupling has been designed for loading and unloading hazardous liquids on ships and/or barges. The Marine version of TODO®'s tried and tested Standard Break-Away Coupling has a more robust design and has been engineered to withstand harsh marine conditions. If excessive load is detected, the coupler closes the valves and then allows disconnection.

TODO® II TANK UNITS

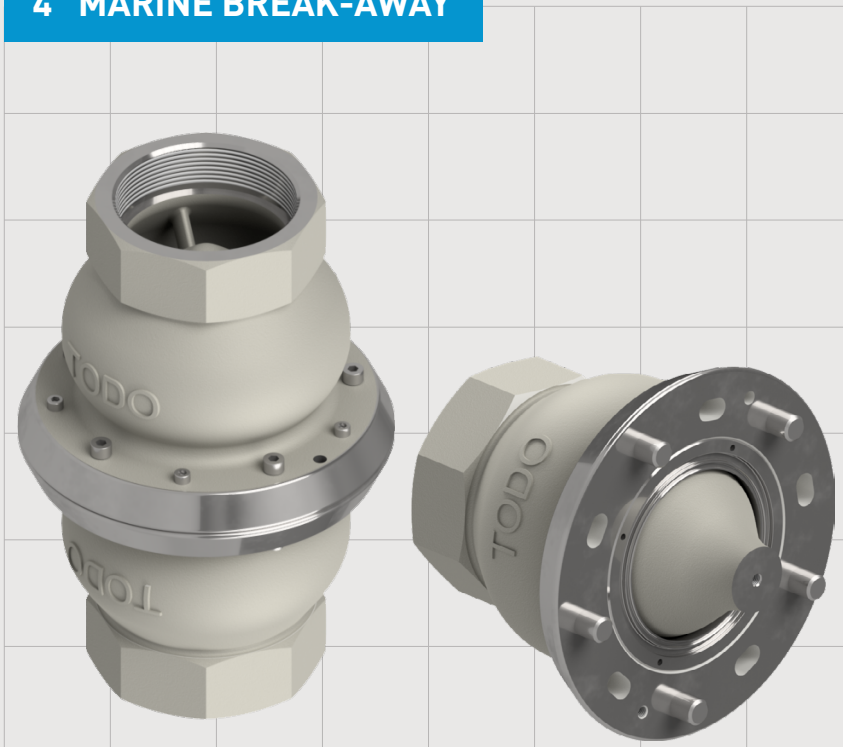
4" MARINE BREAK-AWAYDN100
→HOW
IT
WORKS

- High flow/low pressure drop
- Designed to resist axial force so that disconnect only occurs when subjected to straight pull forces
- Operates independently of shut-off safety systems and does not require an external power source
- Easy to re-set on site

TODO® II TANK UNITS

TODO

05

TODO[®] SAFETY PRESSURE TIGHTCAP (PTC)

DESIGNED WITH BUSINESS NEEDS IN MIND

Created in close collaboration with leading gas and oil companies, the TODO[®] Safety Pressure Tight Cap is designed to assure containment security and operational safety. It is equipped with sensors and failsafes to ensure operator safety and help avoid losses. No other existing closure technology comes close.

TODO[®] II TANK UNITS

TODO

2" (DN 50) PTC | 3" (DN 80) PTC | 4" (DN 100) PTC

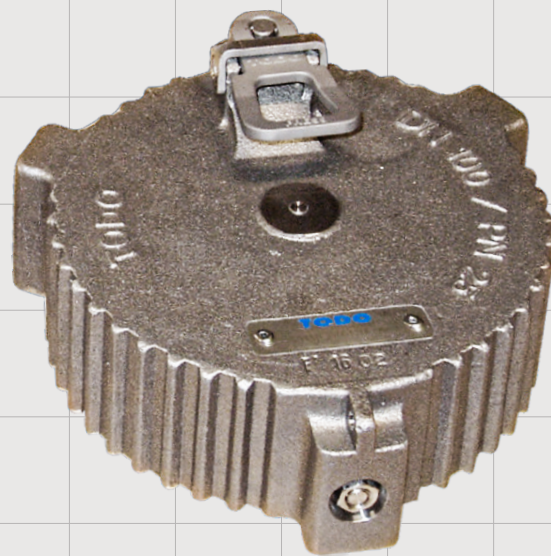
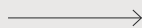
DN50
DN80
DN100

- Pressure indicator alerts the operator to pressure above 1.0 bar behind the cap and possible failure of upstream closure
- Allows for automatic depressurisation
- Reduces static pressure upstream of the cap
- Customs / tamper seal feature
- Suitable for use with all commonly used wire and plastic custom seals

TODO® II TANK UNITS

06

AVIATION COUPLINGS

THE ECONOMICAL ALTERNATIVE FOR AVIATION FUELLING

TODO® Aviation couplings represent real money savings as well as improved safety features and exceptional ease of use to organisations involved in the aviation industry. Their unrivalled reliability and robust design mean lower maintenance and replacement costs. Simple operation reduces human error and improves turnover time. The range includes the TODO®-45 coupling – the first economic alternative to the ISO 45 under wing hose couplers – and the TODO-MATIC® aviation hydrant connection.

TODO® II TANK UNITS

TODO®-45DN65
→

- Automatic valve opening on connection and disconnection
- Simple single action operation, no levers or switches
- Guaranteed valve closure prior to disconnection
- Minimal residual loss on disconnection
- Will connect and disconnect under pressure and flow where necessary
- Robust construction: no external operational components

TODO® II TANK UNITS

TODO

07

TODO® FUEL NOZZLES

DURABLE DESIGN FOR LONG-TERM PERFORMANCE

TODO® fuel nozzles are specifically designed to withstand the pressure of high volume delivery from tanker to the loading station in complete safety. High flow support means faster turnaround times, increasing your profit margins. Operator safety is always key, therefore with less product lost on disconnection and through human error, TODO® fuel nozzles ensure our customers are in safe hands.

TODO® II TANK UNITS

FUEL NOZZLES

1½"
DN 40
→



ACCESSORIES RANGE:

- ✓ TODO-SNAP lug nut
- ✓ TODO-SNAP lug nut with 45° bend
- ✓ Sight glass
- ✓ Dust plug
- ✓ Hook spanner
- ✓ Outlet with extra-long swivelling lug nut
- ✓ Spout
- ✓ Lug nut tool

- Available with or without anti-drain valves
- Automatic handle locking when in closed position
- Optional threaded sight glass
- Ballsealings in PTFE (Teflon®) as standard
- TODO-SNAP log nut equipped on request
- Aluminium alloy components
- Working pressure: PN 10
- Safety factor: 1:5

TODO® II TANK UNITS

08

BALL VALVES

IMPROVED PERFORMANCE, LARGER SAVINGS

TODO®'s lightweight ball valves offer real cash savings to the road and tanker industry. Designed to work specifically in any context which involves regular compartment switching, the ball valves are also used in fixed plant and mobile refuelling applications. The unrivalled sandwich design ensures that quick, easy valve changeover is permitted with a PTFE seal preventing leakage – all of which helps to save businesses time and money.

TODO® II TANK UNITS

ONE WAY BALL VALVES

2" DN50
3" DN80
4" DN100
→

**FEATURES**

- ✓ Aluminium valve body and ball
- ✓ Easy to service
- ✓ PTFE ball sealing
- ✓ Operates under pressure and flow
- ✓ Extremely reliable
- ✓ Robust construction
- ✓ Available with handle or actuator
- ✓ Working Pressure: PN 10
- ✓ Safety factor: 5:1

Ideal for use in road tankers and a variety of plant applications to permit flow in one direction only, TODO® one way ball valves are available with pneumatic actuation and with a wide selection of end connectors.

Available products:

- 4" ball valve with actuator
- 3" ball valve
- 2" ball valve

TODO® II TANK UNITS

TWO WAY BALL VALVES

2" DN50
3" DN80
4" DN100
→

**FEATURES**

- ✓ Aluminium valve body and ball
- ✓ Easy to service
- ✓ PTFE ball sealing
- ✓ Operates under pressure and flow
- ✓ Extremely reliable
- ✓ Robust construction
- ✓ Available with handle or actuator
- ✓ Working Pressure: PN 10
- ✓ Safety factor: 5:1

Offering all the benefits of one way ball valves, the two way ball valves range is ideal for use as a compartment or tank switching valve, to control the direction of flow between either of two outlets.

Available products:

- 4" ball valve with actuator
- 3" ball valve
- 2" ball valve

TODO® II TANK UNITS

09

TODO[®] SWIVEL

IMPROVING MANOEUVRABILITY TO AVOID HOSE FAILURE

One of the biggest causes of premature hose failure – and therefore maintenance costs and wasted time – is torque stress imparted onto the assembly hose by permitting free hose movement. The leading technology in the TODO[®] Swivel avoids this stress, allowing the hose to relax to its natural rest position, whilst permitting its free movement.

TODO[®] II TANK UNITS

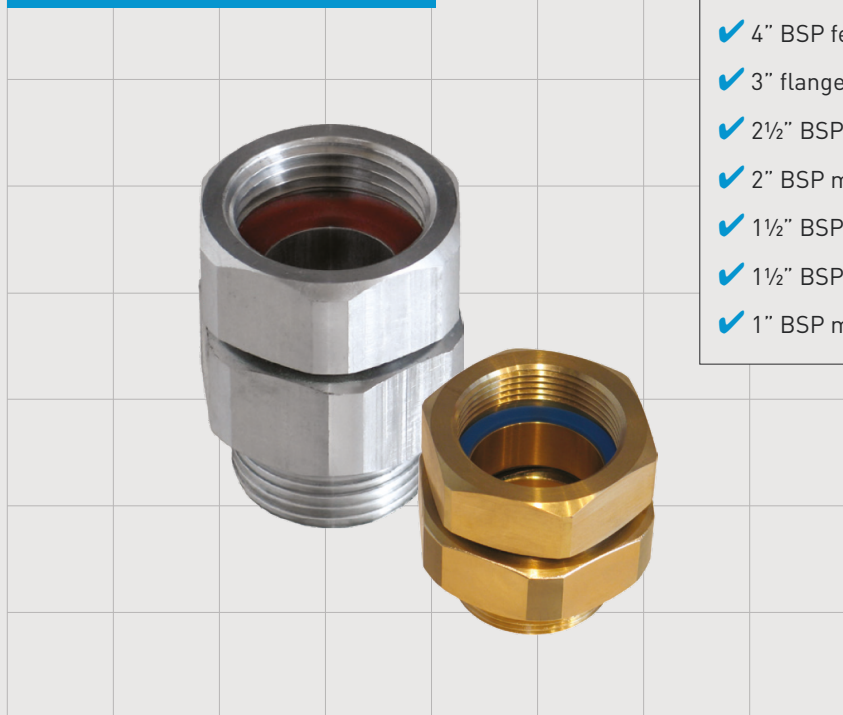
TODO® SWIVEL RANGE0.75" - 4"
→**FEATURES**

- ✓ 4" BSP female - male
- ✓ 3" flange - BSP - male
- ✓ 2½" BSP female - male
- ✓ 2" BSP male - NPT female
- ✓ 1½" BSP male - female
- ✓ 1½" BSP male - male
- ✓ 1" BSP male - female

- Simple design
- Low maintenance
- High reliability
- Very compact
- High flow rate / low pressure drop
- Stainless steel bearings and single o-ring seal

TODO® II TANK UNITS



NEW FEATURES

Reduced Service Time

The new TODO® II Tank Unit has been designed to reduce the amount of time it takes to assemble and disassemble each unit. The internal components can be removed in one piece, the O-ring replaced, and then re-assembled in three easy steps:

- 1 Compress piston and insert 3D printed retainer clip on shaft
- 2 Remove internal assembly and replace O-ring
- 3 Re-fit internal assembly into the body with new lock ring

Weight Reduction

Up to 33% reduction in weight whilst maintaining the high quality of the product and the 5:1 safety factor – i.e. no removal of wall thickness to meet our goals.

Reduced Pressure Drop

The new TODO® II Tank Unit features majorly enhanced flow rates due to:

- Reduced flow turbulence through piston design
- Computer simulated flow in the design of components
- Physically tested flow rates for best in class results

Upgraded Certification - TPED II

Not only have we carried over the high standards of PED certification from the TODO-MATIC® design – we've added TPED to our list of approvals – you'll see a Pi mark on our new TODO® II Tank Unit labels.

TODO® II TANK UNITS

MANUFACTURING FACILITIES

TODO

Channel Road,
Westwood Industrial Estate,
Margate,
Kent,
CT9 4JR UK
Phone +44 (0)1843 221521
Fax +44 (0)1843 295444

SALES OFFICE

Emco Wheaton

Channel Road,
Westwood Industrial Estate,
Margate,
Kent,
CT9 4JR UK
Phone +44 (0)1843 221521
Fax +44 (0)1843 295444

Emco Wheaton GmbH

Emcostraße 2-4,
35274,
Kirchhain,
Germany
Phone +49 6422 84-0
Fax +49 6422 5100

Emco Wheaton USA, Inc.

9111 Jackrabbit Road,
Houston,
Texas,
77095
USA
Phone +1 281 856-1300
Fax +1 281 856-1325

Emco Wheaton France S.A.S.

Division Produits Industriels 70,
Avenue Albert Einstein,
Zone du Château d'Eau
B.P. 50061 - F77551
Moissy-Cramayel Cedex,
France,
Phone +33 1 64 13 89 49
Fax +33 1 64 13 37 08

Emco Wheaton GmbH

Hofherr-Schranz-Gasse 4,
1210 Wien - Österreich,
Austria
Phone +43 1 270 11 99 - 35
Fax +43 1 270 11 99 - 11

Emco Wheaton GmbH

Presnenskaya emb. 10
Block C – Embankment Tower – of. 526
123317 Moscow
Russia
Phone +7 495 9677612
Fax +7 495 9677600

Emco Wheaton Asia Pacific

21-5F IOI Business Park,
Bandar Puchong Jaya,
Puchong, 47170,
Selangor, Malaysia
Phone +603 8075 7500
Fax +603 8075 4100

Gardner Denver International Ltd

PO Box 30804
Diraz, Manama
Bahrain
Phone +973 17813187
Fax +973 17813186

Emco Wheaton

Av. Mercedes Benz,
700 - Distrito Industrial-
Campinas 13054-750,
SP Brazil
Phone +55 19 3765 8303
Mobile +55 19 98168 8516

Gardner Denver Belgium N.V.

Luithagen 7A – Haven 200
B-2030 Antwerpen,
Belgium,
Phone +32 (0)3 541 50 40

Gardner Denver Nederland B.V.

Barwoutswaarder 3
3449HE Woerden
Postbus 299
3440AG
Woerden
Phone +31 (0)348 410150

Gardner Denver Machinery (Shanghai) Co., Ltd.

No. 200 Xin Tuan Rd
Qingpu Industrial Zone
Shanghai
P.R. China
Phone +86 (0) 21 3127 6266
Fax +86 (0) 21 31276206

www.emcowheaton.com/todo-products

www.linkedin.com/company/TODOcouplers