

# Operating Instructions

Fieldbus Profibus 2FC4...-1PB

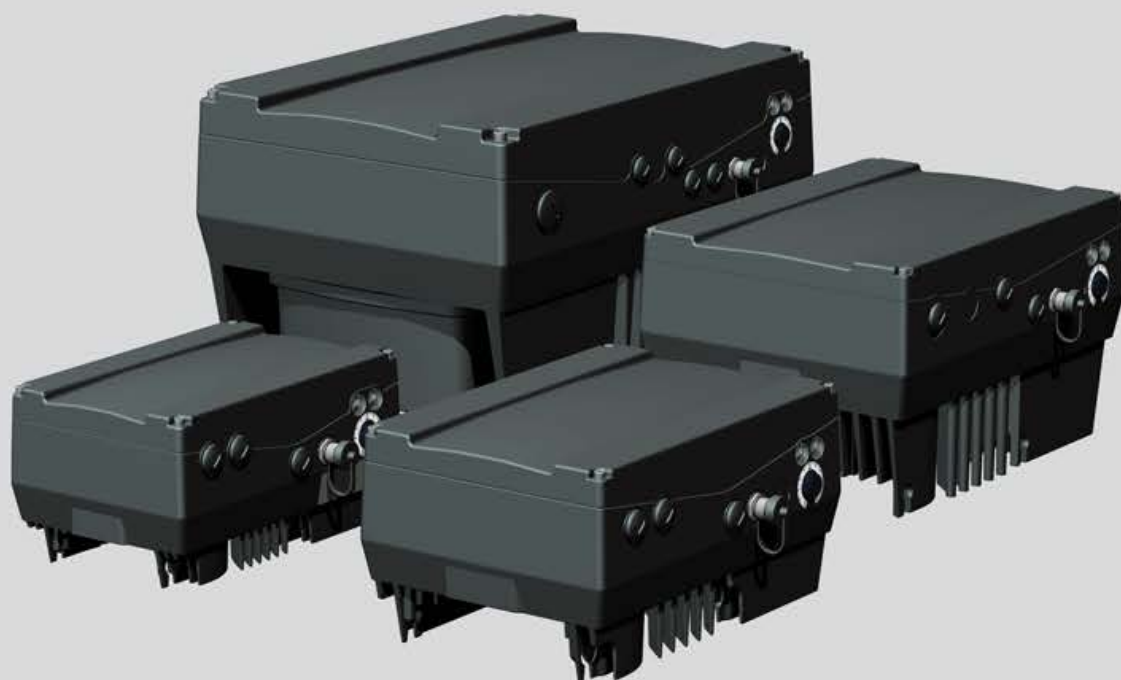

**G-Serie**  
**G-Series**

Seitenkanal  
Side Channel



**C-Serie**  
**C-Series**

Klaue  
Claw



<b>1</b>	<b>Further information .....</b>	<b>3</b>
1.1	Storing the documentation .....	3
1.2	Explanation of the terms and symbols .....	3
1.3	Changes in comparison to the previous version .....	3
1.4	Other valid documents .....	4
<b>2</b>	<b>Safety and responsibility .....</b>	<b>5</b>
2.1	Explanation of warning signs .....	5
2.2	CE Marking .....	5
2.3	Safety instructions .....	5
2.3.1	General information .....	6
2.3.2	Transport and Storage .....	6
2.3.3	Commissioning .....	7
2.3.4	Operation .....	8
2.3.5	Repairs .....	9
2.3.6	Disassembly and Disposal .....	9
2.4	Correct use of the equipment .....	9
2.5	Staff qualifications and training .....	10
2.6	Requirements of the operator .....	10
<b>3</b>	<b>Fieldbus Profibus .....</b>	<b>11</b>
3.1	Hardware Description .....	11
3.2	Data Transfer Rate .....	12
3.3	Setup Drive Controller Address .....	13
3.4	Drive Ccontroller Process Data Out .....	16
3.4.1	Process Data Out .....	17
3.4.2	Process Data Out Adjustable by Parameters .....	17
3.5	Drive Controller Process Data In .....	19
3.5.1	Process Data In .....	19
3.5.2	Process Data In Adjustable by Parameters .....	19
3.6	Drive Controller Control Words .....	20
3.7	Drive Controller Status Words .....	21
3.8	Drive Controller DPV0 Communication .....	22
3.9	Drive Controller DPV1 Communication .....	23
3.10	Error Words .....	24
3.10.1	Error Words Application Board .....	24
3.10.2	Error Words Power Board .....	24
<b>4</b>	<b>Optional accessories .....</b>	<b>25</b>
4.1	Hand-held unit MMI, including 3 m connection cable RJ11 to connector M12 .....	25
4.2	PC communication cable USB to connector M12 (RS485/RS232 converter integrated) .....	25
<b>5</b>	<b>Guidelines, norms and standards .....</b>	<b>26</b>
5.1	EMC limit classes .....	26
5.2	Classification acc. to IEC/EN 61800-3 .....	26
5.3	Standards and guidelines .....	26
5.4	Approval according to UL .....	27
5.4.1	UL Specification (English version) .....	27
5.4.2	Homologation CL (Version en française) .....	30





### 1.1 Storing the documentation

Store this manual and all other applicable documents safely so they are available as and when required.

Provide the operator of the system with this manual so it is available as and when required.

### 1.2 Explanation of the terms and symbols

In these instructions symbols and terms will be used to mean the following.

Symbol	Explanation
!	Requirement, pre-requisite
①	One-step handling instructions
1 2 3	Multi-step handling instructions
✓	Result
[→ 54]	Cross reference with page reference
	Additional information, tips
	General warning sign (warns of risk of injury)
	Electrical voltage warning
	Observe the instructions

Term	Explanation
Plant	Part provided by the user in which the vacuum pump/compressor is installed.
Vacuum pump/compressor	Ready to connect machine for the generation of a vacuum and/or overpressure. The vacuum pump/compressor consists of a compressor part and motor, as well as other accessories where applicable.
Motor	Asynchronous motor for driving the vacuum pump/compressor.
Compressor	Mechanical part of the vacuum pump/compressor without motor.
Assembly environment	Space in which the vacuum pump/compressor is set up and operated (this may differ from the suction environment).
Drive control	Device for rotation speed control of the vacuum pump/compressor. The drive control can be mounted close to the motor (wall assembly) or integrated into the vacuum pump/compressor

### 1.3 Changes in comparison to the previous version

This document has been completely revised in comparison to the version 05.2014 in terms of the writing and the content.

## 1.4 Other valid documents

All instructions that describe the use of the drive control and if applicable, further instructions of all accessory parts used, e.g.

<b>Document number</b>	<b>Purpose</b>
—	Vacuum Pump/Compressor Operating Instructions
610.00260.02.000	Operating Manual 2FC4...-1ST/PB/PN/SC/CB
610.00260.40.020 *	Operating Manual 2FC4...-1PN <b>OR</b>
610.00260.40.030 *	Operating Manual 2FC4...-1SC <b>OR</b>
610.00260.40.040 *	Operating Manual 2FC4...-1CB
610.00260.40.600 *	MMI Hand-Held Unit Operating Manual

\*according to the model option or accessories

Download of 3D files (.stp) for drive control and adapter plates under [www.gd-elmorietschle.com](http://www.gd-elmorietschle.com).

To parameterise the drive control, the parameter description is ready to be downloaded ([www.gd-elmorietschle.com](http://www.gd-elmorietschle.com)). The download contains all necessary information for correct parameterisation.

The manufacturer is not liable for damage caused by the failure to observe these instructions and the related documents [→ 4].

## 2.1 Explanation of warning signs

Warning sign	Explanation
⚠ <b>DANGER</b>	Danger that failure to observe the measures could lead to death or serious physical injuries.
⚠ <b>WARNING</b>	Danger that failure to observe the measures could lead to death or serious physical injuries.
⚠ <b>CAUTION</b>	Danger that failure to observe the measures could lead to minor physical injuries.
<i>NOTICE</i>	Danger that failure to observe the measures could lead to material damage.

## 2.2 CE Marking

With the CE marking, we as the manufacturer of the device confirm that the drive control meets the basic requirements of the following guidelines:

- Directive on Electromagnetic Compatibility (Directive 2004/108/EC of the Council)
- Low Voltage Directive (Directive 2006/95/EC of the Council)

You will find the declaration of conformity for download on [www.gd-elmoritschle.com](http://www.gd-elmoritschle.com).

## 2.3 Safety instructions

The following warnings, precautionary measures and comments are provided for your safety and serve to prevent damage to the drive control and the components connected to it. This chapter contains warnings and information that are generally applicable when handling drive controls. They are split into general information, transport and storage, start-up, operation, repairs and dismantling & disposal.

Specific warnings and comments that apply to specific activities can be found at the start of the appropriate chapters and are repeated and added to at various critical points in these chapters.

Please read this information carefully as it is provided for your personal safety and will also prolong the life of the drive control and connected devices.

### 2.3.1 General information



#### **WARNING**

**This drive controller carries dangerous voltages and controls rotating mechanical parts which may be dangerous!**

**Disregarding the warnings or failure to follow the instructions contained in this manual may lead to death, serious bodily injury or substantial property damage.**

- ① Only qualified personnel should work on this drive controller. These personnel must be thoroughly familiar with all safety instructions, installation, operation and maintenance procedures contained in this manual. The smooth and safe operation of the drive controller depends on proper handling, installation, operation and maintenance.



#### **WARNING**

**Risk of fire or electric shock!**

**Improper use, modifications and the use of spare parts and accessories that are not sold or recommended by the manufacturer of the drive controller can cause fire, electric shock and bodily injury.**

- ① The cooling element of the drive controller and motor can reach temperatures of above **70°C** [158 °F]. During installation, sufficient spacing between adjacent components should be maintained. Before working on the drive controller or motor, required cooling time must be ensured. If necessary, a protection against accidental contact should be installed.

#### **NOTICE**

**The drive controller may be operated safely only if the required ambient conditions are met, see Suitable ambient conditions.**

#### **NOTICE**

**This operating manual must be kept in the vicinity of the equipment, so as to be readily accessible to all users.**

#### **NOTICE**

**Please read these safety instructions and warnings carefully and all the warning labels attached to the equipment before installing and commissioning. Make sure that the warning labels are kept in a legible condition and replace missing or damaged labels.**

### 2.3.2 Transport and Storage

#### **NOTICE**

**Risk of damage to the drive controller!**

**The drive controller can be damaged in the case of non-compliance with the instructions and destroyed during subsequent handling.**

- ① The smooth and safe operation of this drive controller requires proper mounting, installation and assembly as well as careful operation and maintenance. The drive controller must be protected during transport and storage against mechanical shocks and vibration. The protection against excessive temperatures (see Technical data) must be guaranteed.

### 2.3.3 Commissioning



 **DANGER**

**Risk of injury due to electric shock!**

**The non-observance of warnings can result in severe bodily injury or substantial property damage.**

1. Only hard-wired grid connections are permitted. The device must be earthed (DIN EN 61140; VDE 0140-1).
  2. The drive controls may have contact currents > 3.5mA. According to DIN EN 61800-5-1 chapter 4.3.5.5.2, an additional protective earth conductor with the same cross section as the original earth conductor must be attached. The possibility of connecting a second protective earth conductor is located underneath the power supply (with marked ground symbol) on the outside of the device. For the connection, a suitable M6x15 screw (torque: **4.0 Nm** [2.95 ft lbs]) is included in the scope of delivery of the adapter plates.
  3. When using alternating current drive controls, conventional FI circuit breakers of type A, also known as RCDs (residual current-operated protective devices) are not permitted for the protection of direct or indirect contact! As per DIN VDE 0160, section 5.5.2 and EN 50178, section 5.2.11.1, the FI circuit breaker (RCD type B) must be suitable for all types of current.
  4. The following terminals can also lead to dangerous voltages when the engine is at a standstill:
    - ✓ the mains connection terminals X1: L1, L2, L3
    - ✓ the motor connection terminals X2: U, V, W
    - ✓ the connection terminals X6, X7: Relay contacts relays 1 and 2
    - ✓ the PTC connection terminals T1/T2
  5. When using different voltage levels (e.g. +24V/230V), always ensure that lines do not cross! Furthermore, the operator must ensure that the applicable regulations are adhered to (e.g. doubled or reinforced insulation according to DIN EN 61800-5-1).
  6. The drive control contains electrostatically sensitive assemblies. These assemblies can be destroyed due to improper handling, therefore safety measures against electrostatic loading must be adhered to when work must be done on these assemblies.
-

### 2.3.4 Operation



#### DANGER

**>Danger of injury due to electric shocks or restarting motors.  
Non-observance of warnings can result in serious injury or damage.**

① Observe the following instructions during operation:

- ✓ The drive control works with high voltages.
- ✓ When electrical devices are operated, some parts of them are always subject to dangerous voltage.
- ✓ Emergency off equipment according to DIN EN 60204-1; VDE 0113-1:2007-06 has to be functional in all operating modes of the control device. Resetting the emergency stop equipment may not result in uncontrolled or undefined restarting.
- ✓ In order to ensure safe disconnection from the mains, the mains cable has to be all-pole disconnected from the drive control.
- ✓ Certain parameter settings can result in the drive control restarting automatically after the supply voltage has failed.
- ✓ – Devices with single phase supply and devices of the size BG D (11 to 22 kW) must have a pause of 1 to 2 minutes between two sequently power-ons

#### *NOTICE*

**Risk of damaging the drive control!**

**If the notes are not observed, the drive control could be damaged and destroyed during subsequent start-up.**

! Observe the following instructions during operation:

1. For a functioning motor overload protection, the motor parameters must be configured correctly.
2. Ensure the motor overload protection via a PTC. In addition, the drive control provides an internal motor protection. See also parameter 33.100 an 33.101. According to the presetting, the I<sup>2</sup>T is OFF and must be activated during operation without PTC.
3. The drive control may not be used as “Emergency-off equipment” (see DIN EN 60204-1; VDE 0113 1:2007-06).
4. Drive controls are maintenance-free if operated properly. If the air contains dust, the cooling fins of the motor and drive control have to be cleaned regularly.



### 2.3.5 Repairs

**⚠ DANGER**

**Danger of injury through electric shock!**

**Non-observance of warnings may result in serious injury or damage.**

- ① When the drive control is disconnected from the mains voltage, live device parts and connections may not be touched immediately in case the condensers are still live.

**NOTICE**

**Risk of damage to the drive control!**

**If the information is not observed, the drive control could be damaged and destroyed during subsequent start-up.**

- ① Repairs to the drive control may only be performed by the manufacturer.

### 2.3.6 Disassembly and Disposal

**Screw and snap-on connections are easy to release and allow the drive control to be dismantled into its individual parts. These parts can be sorted for recycling. Please comply with local regulations during disposal.**

**Components with electronic parts may not be disposed of along with normal household waste. They have to be collected separately with used electrical and electronic equipment in accordance with applicable legislation.**

### 2.4 Correct use of the equipment

During installation in machinery, commissioning of the drive controller (i.e. starting of intended operation) is prohibited until it is proven that the machine complies with the regulations of the EC Directive 2006/42/EC (Machinery Directive); EN 60204-1:2006 is to be observed.

Commissioning (i.e. starting of intended operation) is only permitted if the EC Directive 2004/108/EC (EMC Directive) allows it.

The harmonised standards of the series EN 50178:1997 in conjunction with EN 60439-1/A1:2004 shall be applied to this drive controller.

This drive controller is not approved for operation in potentially explosive areas!

Repairs may only be carried out by authorised repair workshops. Unauthorised interventions can lead to death, bodily injury and property damage. The warranty provided by the manufacturer expires in this case.

External mechanical loads, such as stepping on the casing are not allowed!

**The use of the drive units in non-stationary equipment is considered as unusual environmental conditions, and is permitted only in accordance with the locally applicable standards and guidelines.**

### 2.5 Staff qualifications and training



All those who will work with the must have read and understood these instructions and the related documents [→ 4].

Personnel in training may only work with the under supervision of personnel who have the **required knowledge**.

Only personnel with the following knowledge may carry out the work described in these instructions:

Qualified personnel, as understood in these operating instructions and product labels, are qualified electricians who are familiar with the installation, assembly, commissioning and operation of the drive controller, as well as the risks associated therewith and have the respective skills on account of their professional training and knowledge of the relevant standards.

### 2.6 Requirements of the operator

As a basic principle, electronic devices are not fail-proof. The operator and/or the contractor setting up the machine or system is responsible for ensuring that the drive switches to a safe state if the device fails.

The “Electrical equipment of machines” section in EN 60204-1, “Safety of machinery” describes the safety requirements for electrical control units. These are provided for the safety of people and machines and must be observed in order to retain the functional capability of the machine or system.

An emergency stop feature does not have to result in the power supply to the drive being switched off. To avoid dangerous situations, it may be useful for individual drives to remain operational or for specific safety procedures to be initiated. The effectiveness of emergency stop measures is evaluated by means of a risk assessment for the machine or system and its electrical equipment, and is determined by selecting a circuit category according to EN 13849 “Safety of machinery – Safety-related parts of control systems”.

The operator ensures that:

- All work on the is carried out by:
  - personnel that have the necessary Staff qualifications and training [→ 10]
  - personnel that have been sufficiently informed of these instructions and all related documents [→ 4]
- Assignment, responsibility and supervision of personnel is regulated.
- The content of these and locally applicable instructions are always available to personnel.
- All local and plant-specific safety measures are adhered to, such as:
  - Prevention of accidents
  - safety and operating regulations
  - Utility company regulations
  - Standards and laws
- Dangers due to electrical energy are not possible.

This chapter contains information on the scope of delivery for the drive control and the function description.

### 3.1 Hardware Description

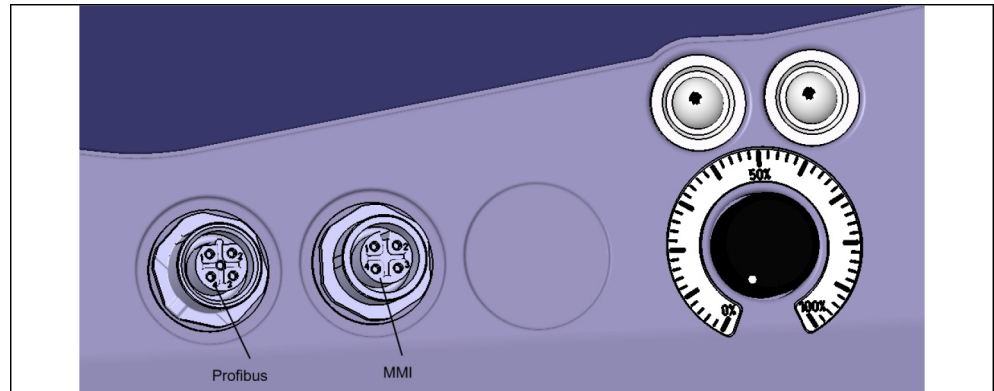

Side view 2x round connector M12, reference value potentiometer and 2x status-LEDs



Round connector, 5-pol., M12, B- encoded for fieldbus profibus

#### Pin allocation of the M12 plug for fieldbus profibus

Pin allocation (w) Device side	
Pin-No.	Signal
1	+5V DC
2	RxD/TxD-N / A-line (green)
3	ground
4	RxD/TxD-P / B-line (red)
5	not occupied
housing	shielding

## Description: Fieldbus Y-piece, complete shielded 12MBaud

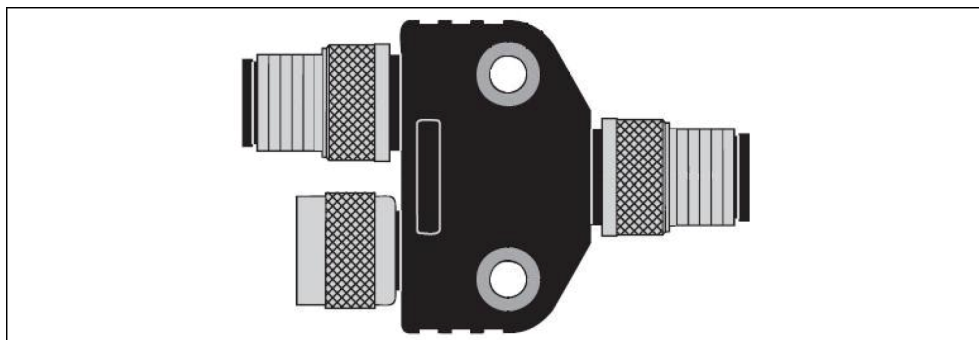

Y-piece (2 x male connector, 1 x female connector), 5-pol., M12, B-coded for fieldbus profibus

Producer: TURCK, Typ VB2-FSW-FKW-FSW-45

Art.-No.: 6996009

Producer: BECKHOFF

Art.-No.: ZS1000-2600

Producer: ESCHA

Art.-No.: 8011228

## Description: Passive resistance (male connector)



Passive resistance (male connector), 5-pol., M12, B-coded for fieldbus profibus

Producer: TURCK, Typ RSS4.5-PDP-TR

Art.-No.: 6601590

Producer: BECKHOFF

Art.-No.: ZS1000-1610

Producer: ESCHA

Art.-No.: 8043520

## 3.2 Data Transfer Rate

From the user-side the data transfer rate can be selected in an area of 9.6 kbit/s to 12 Mbit/s. The selection is done when the fieldbus is operated and applies for all the participants.

The maximum length of a segment is reciprocally proportional to the data transfer rate.

### Pin allocation of the M12 plug for fieldbus profibus

Data transfer rate (kbit/s)	9.6	19.2	93.75	187.5	500	1,500	3,000	6,000	12,000
Length/segment (m)	1,200	1,200	1,200	1,000	400	200	100	100	100

In order to allow bigger cable lengths the application of repeater is possible.

- At the appropriate ends of the bus terminating resistors have to be installed.
- Place the bus and power cable as far from each other as possible (min. 30 cm).
- With potentially appearing pf crossing cables an angle of 90° should be maintained if possible.
- Without use of a repeater max. 32 drive controllers can be connected to one fieldbus line.

## 3.3 Setup Drive Controller Address

A drive controller in a fieldbus is definitely identified through its particular address. The address of a drive controller, for use in a profibus-network, should be adjusted between 0 and 125.

General information for addressing:

- The addresses 0 are generally reserved for diagnosis tools, such as e. g. programming units.
- The addresses of the master stations should begin with the lowest addresses. So a single master has the address 1, further masters have the address 2, 3 etc then. In a profibus-network with one master remain max. 124 free slave-stations.
- The address 126 is normally reserved as delivery address (default value) for stations, which address can be set over the fieldbus (SSA-service).
- The address 127 is reserved for addressing to all or respectively to groups (broadcast) and therefore can't be set at a station.
- Repeater, coupler and LWL-converter transmit their telegrams transparent from segment to segment, therefore they need no own address.

The appropriate valid drive control-address complies with the binary number which results from the position of the rotary switch 1 (DS1) and the rotary switch 2 (DS2).

In delivery status both rotary switches are preset to the value 0. In this status the addressing can be carried out by means of the parameter fieldbus address (6.060). By means of the parameters fieldbus baud rate (6.061) and bus timeout (6.062) further settings can be done.

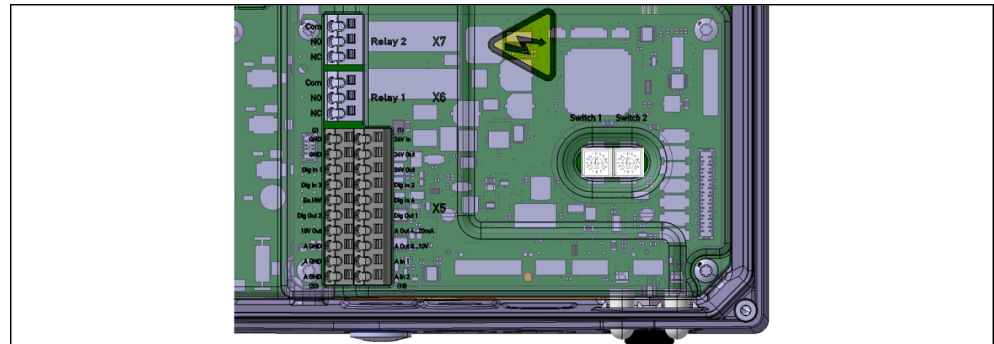

Switch 1 (DS1) and Switch 2 (DS2) for setting of the hardware field bus address

### Setting fieldbus address with rotary switches DS1 und DS2

Address		Settings	
DECIMAL	HEX	DS1	DS2
0	0	0	0
1	1	1	0
2	2	2	0
3	3	3	0
4	4	4	0
5	5	5	0
6	6	6	0
7	7	7	0
8	8	8	0
9	9	9	0
10	a	a	0
11	b	b	0

Adress		Settings	
DECIMAL	HEX	DS1	DS2
12	c	c	0
13	d	d	0
14	e	e	0
15	f	f	0
16	10	0	1
17	11	1	1
18	12	2	1
19	13	3	1
20	14	4	1
21	15	5	1
22	16	6	1
23	17	7	1
24	18	8	1
25	19	9	1
26	1a	a	1
27	1b	b	1
28	1c	c	1
29	1d	d	1
30	1e	e	1
31	1f	f	1
32	20	0	2
33	21	1	2
34	22	2	2
35	23	3	2
36	24	4	2
37	25	5	2
38	26	6	2
39	27	7	2
40	28	8	2
41	29	9	2
42	2a	a	2
43	2b	b	2
44	2c	c	2
45	2d	d	2
46	2e	e	2
47	2f	f	2
48	30	0	3
49	31	1	3
50	32	2	3
51	33	3	3
52	34	4	3
53	35	5	3
54	36	6	3
55	37	7	3

Adress		Settings	
DECIMAL	HEX	DS1	DS2
56	38	8	3
57	39	9	3
58	3a	a	3
59	3b	b	3
60	3c	c	3
61	3d	d	3
62	3e	e	3
63	3f	f	3
64	40	0	4
65	41	1	4
66	42	2	4
67	43	3	4
68	44	4	4
69	45	5	4
70	46	6	4
71	47	7	4
72	48	8	4
73	49	9	4
74	4a	a	4
75	4b	b	4
76	4c	c	4
77	4d	d	4
78	4e	e	4
79	4f	f	4
80	50	0	5
81	51	1	5
82	52	2	5
83	53	3	5
84	54	4	5
85	55	5	5
86	56	6	5
87	57	7	5
88	58	8	5
89	59	9	5
90	5a	a	5
91	5b	b	5
92	5c	c	5
93	5d	d	5
94	5e	e	5
95	5f	f	5
96	60	0	6
97	61	1	6
98	62	2	6
99	63	3	6

Adress		Settings	
DECIMAL	HEX	DS1	DS2
100	64	<b>4</b>	<b>6</b>
101	65	<b>5</b>	<b>6</b>
102	66	<b>6</b>	<b>6</b>
103	67	<b>7</b>	<b>6</b>
104	68	<b>8</b>	<b>6</b>
105	69	<b>9</b>	<b>6</b>
106	6a	<b>a</b>	<b>6</b>
107	6b	<b>b</b>	<b>6</b>
108	6c	<b>c</b>	<b>6</b>
109	6d	<b>d</b>	<b>6</b>
110	6e	<b>e</b>	<b>6</b>
111	6f	<b>f</b>	<b>6</b>
112	70	<b>0</b>	<b>7</b>
113	71	<b>1</b>	<b>7</b>
114	72	<b>2</b>	<b>7</b>
115	73	<b>3</b>	<b>7</b>
116	74	<b>4</b>	<b>7</b>
117	75	<b>5</b>	<b>7</b>
118	76	<b>6</b>	<b>7</b>
119	77	<b>7</b>	<b>7</b>
120	78	<b>8</b>	<b>7</b>
121	79	<b>9</b>	<b>7</b>
122	7a	<b>a</b>	<b>7</b>
123	7b	<b>b</b>	<b>7</b>
124	7c	<b>c</b>	<b>7</b>
125	7d	<b>d</b>	<b>7</b>
<b>126</b>	<b>7e</b>	<b>e</b>	<b>7</b>
<b>127</b>	<b>7f</b>	<b>f</b>	<b>7</b>

Do not use the **bold** marked addresses (**0, 1, 126, 127**) for addressing/ programming the drive controller!

### 3.4 Drive Ccontroller Process Data Out

---

The 32bit data (error words, digital out, digital in) are fragmented in 16bit data, because there is a limitation of the data width in some fieldbus systems. If there is 32bit data processing possible, the 32bit word is used, whatever words are using (low- or high-word)!

---



### 3.4.1 Process Data Out

#### Process Data Out

Adress	Data Type	Definition	Unit	Description
0x0000	WORD*	status word	-	not adjustable
0x0004	REAL	actual frequency	Hz	not adjustable
0x0008	REAL	process data out 3 (motor voltage)	V	adjustable with PC tool
0x000C	REAL	process data out 4 (motor current)	A	adjustable with PC tool
0x0010	REAL	process data out 5 (mains voltage)	V	adjustable with PC tool
0x0014	REAL	process data out 6 (frequency reference value)	Hz	adjustable with PC tool
0x0018	DWORD*	process data out 7 (digital inputs bit encoded)	-	adjustable with PC tool
0x001C	REAL	process data out 8 (analog input 1)	V	adjustable with PC tool
0x0020	DWORD*	process data out 9 (error word 1)	-	adjustable with PC tool
0x0024	DWORD*	process data out 10 (error word 2)	-	adjustable with PC tool

\*Data type WORD equivalent UINT16

\*Data type DWORD equivalent UINT32

### 3.4.2 Process Data Out Adjustable by Parameters

#### Process Data Out Adjustable by Parameters

run No.	Data type	Available SW-Vers.	Definition	Unit	Description
0	REAL		mechanical speed	Hz	without consideration of the number of pole pairs
1	REAL		output voltage	V	motor voltage
2	REAL		motor current	A	
3	REAL		IGBT temperature	°C	
4	REAL		DC bus voltage	V	
5	REAL		frequency reference value	Hz	
6	REAL		mains voltage	V	input voltage
7	REAL		DC bus current	A	
8	REAL		internal temperature	°C	FU-internal temperature
9	REAL		speed encoder	Hz	only with option encoder
10	t.b.d.		position encoder	°	only with option encoder
11	DWORD*		error application	1	bit encoded

run No.	Data type	Available SW-Vers.	Definition	Unit	Description
13	DWORD*		error power	1	bit encoded
15	DWORD*		digital inputs (1..4+chopper-approval)	1	bit encoded
16	REAL		analog in 1	V	analog input 1 application
17	REAL		analog in 2	V	analog input 2 application
18	REAL		frequency reference value after ramp	Hz	frequency reference value after ramp
19	REAL		frequency reference value	Hz	frequency reference value
20	REAL		PID feedback	%	PID feedback
21	REAL		PID reference	%	PID reference
22	REAL		analog out 1	V	analog out 1
23	REAL		DC bus power	W	DC bus power
24	REAL		reserved	-	reserved
25	REAL		reserved	-	reserved
26	REAL		reserved	-	reserved
27	REAL		reserved	-	reserved
28	REAL		reserved	-	reserved
29	DWORD*		Status word fieldbus/PLC	1	Status word fieldbus/PLC
30	REAL	03.02	mechanical speed	U/min	mechanical speed
31	REAL	03.02	motor torque	Nm	motor torque
32	REAL	03.02	electrical motor power	W	electrical motor power
33	DWORD*	03.04	virtual digital output (lowWord)	1	customer PLC output variable
35	REAL	03.04	customer PLC output variable 1	1	customer PLC output variable 1
36	REAL	03.04	customer PLC output variable 2	1	customer PLC output variable 2
37	REAL	03.04	customer PLC output variable 3	1	customer PLC output variable 3
38	DWORD*	03.05	operating period	1	operating period
39	DWORD*	03.05	power on-cycle	1	power on-cycle
40	REAL	03.05	electrical energy	Wh	electrical energy
41	DWORD*	03.05	status output (digout1+2, relay 1+2)		status output

\*Data type DWORD equivalent UINT32

### 3.5 Drive Controller Process Data In

The 32bit data (error words, digital out, digital in) are fragmented in 16bit data, because there is a limitation of the data width in some fieldbus systems. If there is 32bit data processing possible, the 32bit word is used, whatever words are using (low- or high-word)!

#### 3.5.1 Process Data In

##### Process Data In

Adress	Data Type	Definition	Unit	Description
0x0000	WORD*	control word		not adjustable
0x0004	REAL	reference value	%	not adjustable
0x0008	DWORD*	process data in 3 (digital output 1- relay)		adjustable with PC tool
0x000C	REAL	process data in 4 (analog output 1)	V	adjustable with PC tool
0x0010		process data in 5 (reserved)		adjustable with PC tool
0x0014		process data in 6 (reserved)		adjustable with PC tool

\*Data type WORD equivalent UINT16

\*Data type DWORD equivalent UINT32

#### 3.5.2 Process Data In Adjustable by Parameters

##### Process Data In Adjustable by Parameters

run No.	Data Type	Available SW-Vers.	Definition	Unit	Description
0	DWORD*	03.02	digital – relay - outputs	1	digital – relay - outputs
1	REAL	03.02	analog out 1	V	analog out 1
2	DWORD*	03.04	virtual digital input	1	software PLC virtual digital input
4	REAL	03.04	customer PLC input variable 1	1	software PLC input variable 1
5	REAL	03.04	customer PLC input variable 2	1	software PLC input variable 2
6	REAL	03.04	customer PLC input variable 3	1	software PLC input variable 3

\*Data type DWORD equivalent UINT32

## 3.6 Drive Controller Control Words

Control word 1 (STW1)

### Control Words

Bit	Value	Meaning	Description
0	1*	ON	operative, i.e. main contactor on, net voltage lies against the FC and HW release
	0	OFF 1	stopping via ramp
1	1*	operating condition	OFF 2 condition off
	0	electr. stop (OFF 2)	PWM off, free run out
2	1*	operating condition	operating condition
	0	Fast stop (OFF 3)	stopping via fastest ramp
3	1*	impuls release	Operation released, PWM on
	0	impulse lock	Operation locked, free run out, PWM off
4	1*	operating condition	operating condition
	0	RFG lock	<sup>1</sup> OFF 3 stopping via fastest ramp
5	1	RFG release	<sup>1</sup> Nicht implementiert
	0	RFG stop	<sup>1</sup> Nicht implementiert
6	1*	reference value release	Addressed value at the input of the RFG is turned on
	0	reference value lock	Addressed value at the input of the RFG is set to 0.
7	1	error quitting (0 -> 1)	accumulative quitting on pos. edge
8	1	JOG (right)	<sup>1</sup> not implemented
	0		<sup>1</sup> not implemented
9	1	JOG (left)	<sup>1</sup> not implemented
	0		<sup>1</sup> not implemented
10	1*	control from PLC	command over interface, process data valid
	0		no command over interface, process data invalid
11	1	device specific	-
	0		
12	1	device specific	-
	0		
13	1	device specific	-
	0		
14	1	device specific	-
	0		
15	1	device specific	-
	0		

RFG: ramp function generator

\* operating condition

<sup>1</sup> deviation from standard

### 3.7 Drive Controller Status Words

Status word 1 (ZSW1)

#### Status Words

Bit	Value	Meaning	Description
0	1	ready for operation	Net contactor on, current supply on, no error
	0	not ready for operation	
1	1	ready for operation	see control word Bit 0 (main contactor on, net voltage lies against the FC and HW release), no error
	0	not ready for operation	
2	1	operation / impulse release	see control word Bit 3
	0	operation locked	
3	1	error active	there is an error
	0	trouble-free	
4	1	electr. Stop active (OFF 2)	OFF 2 command is active
	0	no OFF 2	
5	1	fast Stop active (OFF 3)	OFF 3 command is active
	0	No OFF 3	
6	1	switch lock active	<sup>1</sup> Operation locked
	0	no switch lock	<sup>1</sup> Operation released
7	1	warning active	<sup>2</sup> drive further in operation, no quitting
	0	no warning	<sup>2</sup> there is no warning or warning disappeared
8	1	deviation reference and current value in the tolerance area	Actual value inside a tolerance area; dynamical over- and under runs for $t < t_{max}$ acceptable e.g. $f = f_{ref} \pm f$ , etc. $t_{max}$ is adjustable by parameters
	0	deviation reference and current value not in the tolerance area	
9	1	control from PLC	the automation system is asked to take the command
	0	no control from PLC	command possible only with device
10	1	reference frequency/reference speed reached	actual value $\geq$ comparative value (reference value) which is adjustable over the parameter number
	0	reference frequency/reference speed under run	actual value $<$ comparative value
11	1	device specific	meaning not given
	0	-	
12	1	device specific	meaning not given
	0	-	

Bit	Value	Meaning	Description
13	1	device specific	meaning not given
	0	-	
14	1	device specific	meaning not given
	0	-	
15	1	device specific	meaning not given
	0	-	

PLC: programmable logic controller / automation device

<sup>1</sup> deviation from standard

<sup>2</sup> beginning with SW 03.61

### 3.8 Drive Controller DPV0 Communication

With the DPV0 communication (cyclically) the 20 modules word input con(0x40,0xD3) and 12 word output con(0xEB) are fix and not changeable in the inverter configured.

These have to be adapted from the .gsd-file into the appropriate slave configuration (see image below). Please install "GardnerDenver\_2FC4\_\_\_-1PB.gsd", download under: [www.gd-elmoritschle.com](http://www.gd-elmoritschle.com).

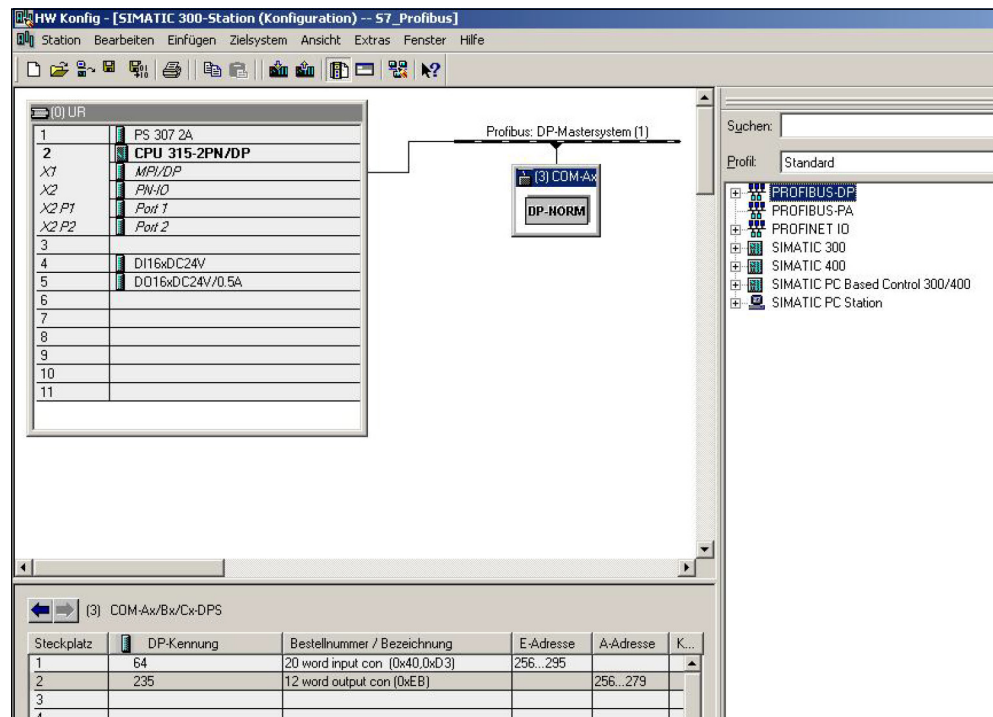

The screenshot shows the HW Config interface for a SIMATIC 300 station. The main window displays the hardware rack configuration, including a PS 307 2A power supply, a CPU 315-2PN/DP, and various modules. A Profibus DP-Master system (1) is connected to a DP slave (COM-Ax DP-NORM). The DP slave configuration table is shown below:

Steckplatz	DP-Kennung	Bestellnummer / Bezeichnung	E-Adresse	A-Adresse	K...
1	64	20 word input con (0x40,0xD3)	256...295		
2	235	12 word output con (0xEB)		296...279	
3					
4					

Integration of the gsd-File

## 3.9 Drive Controller DPV1 Communication

With the DPV1 communication (acyclically) the parameters are addressed over a slot and an index (see image). The access occurs over a library function SFB52 (read parameter) and SFB53 (write parameter) provided from Siemens.

### DPV1 Communication

Parameter		Profibus	
INDEX	Definition	Slot	Index
0	minimal frequency	1	0
1	maximal frequency	1	1
2	not applied	1	2
...		...	...
254	Free	1	254
255	Free	1	255
256	not applied	2	0
257	not applied	2	1
...		...	...

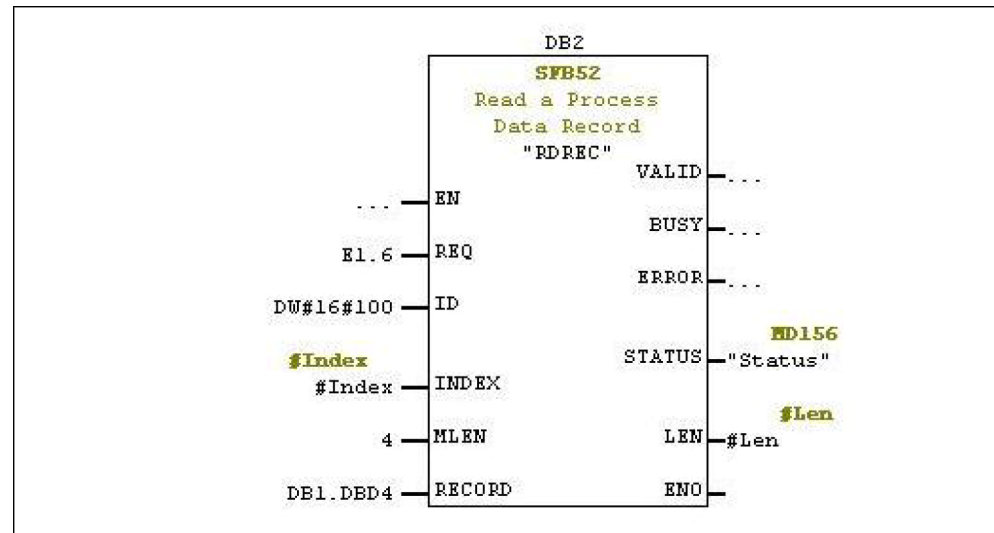

Example of the Read Variables

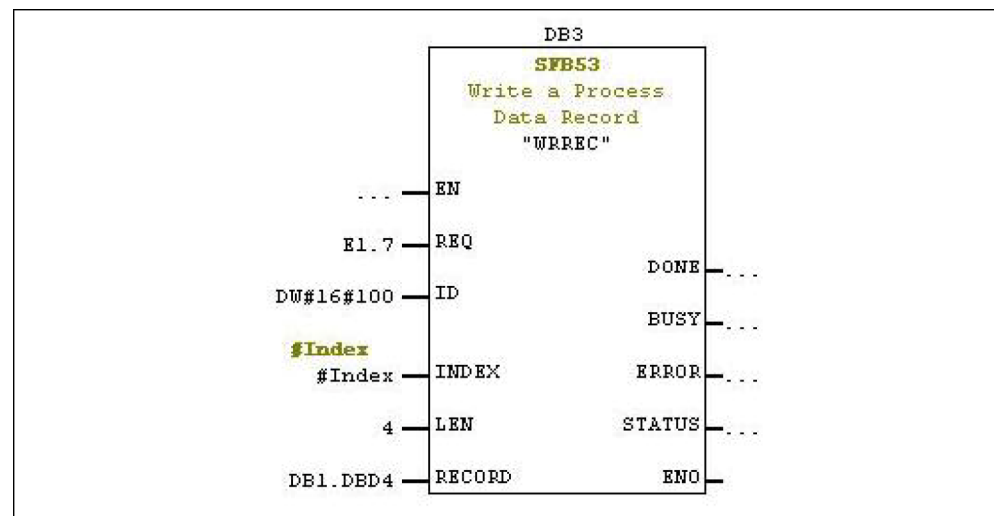

Example of the Write Variables

## 3.10 Error Words

### 3.10.1 Error Words Application Board

#### Error Words Application Board

Bit	Fault No.	Description
0	1	Under voltage 24V application
1	2	Over voltage 24V application
7	8	Communication application <> power
9	10	Parameter allocation
12	13	Cable break analog in 1 (4..20mA / 2 - 10V)
13	14	Cable break analog in 2 (4..20mA / 2 - 10V)
14	15	Stall detection
21	22	Reset fault
22	23	External fault 1
23	24	External fault 2
24	25	Fault selfcom

### 3.10.2 Error Words Power Board

#### Error Words Power Board

Bit	Fault No.	Description
0	32	Trip IGBT
1	33	Over voltage DC- bus
2	34	Under voltage DC- bus
3	35	Over temperature motor
4	36	Mains interruption
6	38	IGBT over temperature
7	39	Over current
8	40	Controller over temperature
10	42	I <sup>2</sup> T motor protection
11	43	Earth fault
13	45	Motor disconnected
14	46	Motor parameters
15	47	Controller parameter
16	48	Name plate
17	49	Power limitation



This chapter contains brief descriptions of the following optional accessories

- Manual hand-held control unit including connection cable RJ11 on plug M12
- PC communication cable USB on M12 plug (converter RS485/RS232 integrated)

#### **4.1 Hand-held unit MMI, including 3 m connection cable RJ11 to connector M12**

The hand-held unit MMI 2FX4520-0ER00 is a purely industrial product (accessory) which may only be used in conjunction with a DRIVE CONTROLLER! The HAND-HELD UNIT MMI is connected to the integrated M12 interface of the drive controller. By means of this control unit, the user is able to write (program) and/or display all parameters of the drive controller. Up to 8 complete records can be stored in a HAND-HELD UNIT MMI and copied to other DRIVE CONTROLLERS. As an alternative to free PC software, complete commissioning is possible, external signals are not necessary.

#### **4.2 PC communication cable USB to connector M12 (RS485/RS232 converter integrated)**

As an alternative to the MMI hand-held unit, a drive control can also be commissioned with the help of the PC adapter 2FX4521-0ER00 and the PC software. The PC software is available to you free of cost on the manufacturer homepage under [www.gd-elmorietschle.com](http://www.gd-elmorietschle.com).

This chapter contains information about electromagnetic compatibility (EMC), and guidelines, norms and standards.

For binding information about the relevant drive control approvals, please refer to the relevant type plate!

### 5.1 EMC limit classes

Please note that EMC limit classes are only reached if the standard switching frequency (clocking frequency) of 8 kHz is complied with. Depending on the installation material used and/or extreme ambient conditions, it might be necessary to use additional sheath wave filters (ferrite rings). If the device is mounted on the wall, the length of the shielded motor cables (with large surfaces on both sides) (max. 3 m) may not exceed the permitted limits.

Wiring suitable for EMC also requires that EMC screw connections be used on both sides (drive control and motor).

#### **NOTICE**

**In a residential environment, this product can cause high-frequency disruptions that may require interference suppression measures.**

### 5.2 Classification acc. to IEC/EN 61800-3

The generic standard defines test procedures and severity levels for every environment in the drive control category; these have to be complied with.

#### **Definition of environment**

First environment (residential, commercial and industrial area):

All "areas" that are directly supplied by a public low-voltage connection, such as:

- Residential area, e.g. houses, apartments etc.
- Retail area, e.g. shops, supermarkets
- Public institutions, e.g. theatres, stations
- Outside areas, e.g. petrol stations and parking areas
- Light industry, e.g. workshops, laboratories, small businesses

Second environment (industry):

Industrial surroundings with their own supply network that is separated from the public low-voltage supply by a transformer.

### 5.3 Standards and guidelines

The following specifically apply:

- Directive on Electromagnetic Compatibility (Directive 2004/108/EC of the Council EN 61800-3:2004)
- Low Voltage Directive (Directive 2006/95/EC of the Council EN 61800-5-1:2003)
- Product standards list

## 5.4 Approval according to UL

### 5.4.1 UL Specification (English version)

#### Maximum Ambient Temperature (without models Suffix S10):

Electronic	Adapter	Ambient	Suffixe
INV MA 2 0.37	ADP MA WDM	45° C	-
INV MA 2 0.55	ADP MA WDM	45° C	-
INV MA 2 0.75	ADP MA WDM	45° C	-
INV MA 2 1.10	ADP MA WDM	40° C	-
INV MA 4 1.50	ADP MA WDM	40° C	-
INV MB 4 2.2	ADP MB WDM	45° C	-
INV MB 4 3.0	ADP MB WDM	40° C	-
INV MB 4 4.0	ADP MB WDM	35° C	-
INV MC 4 5.5	ADP MC WDM	40° C	Gx0
INV MC 4 7.5	ADP MC WDM	35° C	Gx0
INV MC 4 5.5	ADP MC WDM	55° C	Gx1
INV MC 4 7.5	ADP MC WDM	50° C	Gx1
INV MC 4 5.5	ADP MC WDM	50° C	Gx2
INV MC 4 7.5	ADP MC WDM	45° C	Gx2
INV MD 4 11.0	ADP MD WDM	55° C	-
INV MD 4 15.0	ADP MD WDM	50° C	-
INV MD 4 18.5	ADP MD WDM	40° C	-
INV MD 4 22.0	ADP MD WDM	35° C	-

#### Maximum Surrounding Temperature:

Electronic	Adapter	Ambient	Suffixe
INV MC 4 5.5	ADP MC WDM	40° C	S10
INV MC 4 7.5	ADP MC WDM	35° C	S10

#### Required Markings

Enclosure intended for use with field-installed conduit hubs, fittings or closure plates UL approved in accordance to UL514B and CSA certified in accordance to C22.2 No. 18, environmental Type 1 or higher.

The INVEOR INV MC 4 with suffix S10 is for use in Pollution Degree 2 only.

Internal Overload Protection Operates within 60 seconds when reaching 150 % of the Motor Full Load Current

Suitable for use on a circuit capable of delivering not more than 5 kA rms symmetrical amperes, 230 Volts for INV Mx 2 or 480 Volts for INV Mx 4, maximum when protected by fuses.

“Warning” – Use fuses rated 600 V/50 A for INV MA 2 only.

“Warning” – Use fuses rated 600 V/10 A for INV MA 4 only.

“Warning” – Use fuses rated 600 V/30 A for INV MB 4 only.

“Warning” – Use fuses rated 600 V/30 A for INV MC 4 only.

“Warning” – Use fuses rated 600 V/70 A for INV MD 4 only.

Integral solid state short circuit protection does not provide branch circuit protection. Branch circuit protection must be provided in accordance with the Manufacturer Instructions, National Electrical Code and any additional local codes.

All wiring terminals marked to indicate proper connections for the power supply, load and control circuitry.

The tightening, torque to connect the motor terminals, is 26.55 lb/in (size A to C) and 5.31 lb/in to connect the PTC (in all sizes).

**Instruction for operator and servicing instructions on how to mount and connect the products using the intended motor connection adapter, please see Installing the drive controller integrated in the motor and Adapter plates in the operating manual.**

Use 75° C copper wires only.

Drives do not provide over temperature sensing.

For Mx 4 used in Canada: TRANSIENT SURGE SUPPRESSION SHALL BE INSTALLED ON THE LINE SIDE OF THIS EQUIPMENT AND SHALL BE RATED 277 V (PHASE TO GROUND), 480 V (PHASE TO PHASE), SUITABLE FOR OVER-VOLTAGE CATEGORY III, AND SHALL PROVIDE PROTECTION FOR A RATED IMPULSE WITHSTAND VOLTAGE PEAK OF 2.5 kV

### Maximum Surrounding Temperature (sandwich version):

Electronic	Overall heatsink dimensions	Surrounding	Suffix
INV MA 2 0.37	(150x27x210) mm	50° C	Gx3
INV MA 2 0.55	(150x27x210) mm	50° C	Gx3
INV MA 2 0.75	(150x27x210) mm	50° C	Gx3
INV MA 2 1.10	(150x27x210) mm	50° C	Gx3
INV MA 4 0.55	(150x27x210) mm	65° C	Gx3
INV MA 4 0.75	(150x27x210) mm	65° C	Gx3
INV MA 4 1.10	(150x27x210) mm	65° C	Gx3
INV MA 4 1.50	(150x27x210) mm	65° C	Gx3
INV MB 4 2.2	(200x40x250) mm	60° C	Gx3
INV MB 4 3.0	(200x40x250) mm	60° C	Gx3
INV MB 4 4.0	(200x40x250) mm	60° C	Gx3
INV MC 4 5.5	(216x83x300) mm	65° C	Gx3
INV MC 4 7.5	(216x83x300) mm	65° C	Gx3
INV MD 4 11.0	to be defined	to be defined	Gx3
INV MD 4 15.0	to be defined	to be defined	Gx3
INV MD 4 18.5	to be defined	to be defined	Gx3
INV MD 4 22.0	to be defined	to be defined	Gx3

### CONDITIONS OF ACCEPTABILITY:

**Use** - For use only in complete equipment where the acceptability of the combination is determined by Underwriters Laboratories Inc.

1. These drives are incomplete in construction and have to be attached to an external heatsink in the end-use. Unless operated with the heatsink as noted in item 2 of the conditions of acceptability below, temperature test shall be conducted in the end-use.
2. Temperature test was conducted with drive installed on aluminum heatsink, overall dimensions and ribs shape as outlined below:
3. Suitability of grounding for the combination of drive and heatsink needs to be verified in accordance with the end-use standard.

4. Temperature test was not conducted on models INV MD 4. Suitability of drive - heatsink combination shall be determined by subjecting to temperature test in the end-use.

### Required Markings

Internal Overload Protection Operates within 60 seconds when reaching 150 % of the Motor Full Load Current.

Suitable for use on a circuit capable of delivering not more than 5 kA rms symmetrical amperes, 230 Volts for INV Mx 2 or 480 Volts for INV Mx 4, maximum when protected by fuses.

“Warning” – Use fuses rated 600 V/50 A for INV MA 2 only.

“Warning” – Use fuses rated 600 V/10 A for INV MA 4 only.

“Warning” – Use fuses rated 600 V/30 A for INV MB 4 only.

“Warning” – Use fuses rated 600 V/30 A for INV MC 4 only.

“Warning” – Use fuses rated 600 V/70 A for INV MD 4 only.

Integral solid state short circuit protection does not provide branch circuit protection. Branch circuit protection must be provided in accordance with the Manufacturer Instructions, National Electrical Code and any additional local codes.

All wiring terminals marked to indicate proper connections for the power supply, load and control circuitry.

**Instruction for operator and servicing instructions on how to mount and connect the products using the intended motor connection adapter, please see Installing the drive controller integrated in the motor and Adapter plates in the operating manual.**

Use 75° C copper wires only.

Drives do not provide over temperature sensing.

For use in Pollution degree 2 only.

For Mx 4 used in Canada: TRANSIENT SURGE SUPPRESSION SHALL BE INSTALLED ON THE LINE SIDE OF THIS EQUIPMENT AND SHALL BE RATED 277 V (PHASE TO GROUND), 480 V (PHASE TO PHASE), SUITABLE FOR OVER-VOLTAGE CATEGORY III, AND SHALL PROVIDE PROTECTION FOR A RATED IMPULSE WITHSTAND VOLTAGE PEAK OF 2.5 kV

## 5.4.2 Homologation CL (Version en française)

## Température ambiante maximale (sans modèles suffixe S10):

Électronique	Adaptateur	Ambiante	Suffixe
INV MA 2 0.37	ADP MA WDM	45° C	-
INV MA 2 0.55	ADP MA WDM	45° C	-
INV MA 2 0.75	ADP MA WDM	45° C	-
INV MA 2 1.10	ADP MA WDM	40° C	-
INV MA 4 1.50	ADP MA WDM	40° C	-
INV MB 4 2.2	ADP MB WDM	45° C	-
INV MB 4 3.0	ADP MB WDM	40° C	-
INV MB 4 4.0	ADP MB WDM	35° C	-
INV MC 4 5.5	ADP MC WDM	40° C	Gx0
INV MC 4 7.5	ADP MC WDM	35° C	Gx0
INV MC 4 5.5	ADP MC WDM	55° C	Gx1
INV MC 4 7.5	ADP MC WDM	50° C	Gx1
INV MC 4 5.5	ADP MC WDM	50° C	Gx2
INV MC 4 7.5	ADP MC WDM	45° C	Gx2
INV MD 4 11.0	ADP MD WDM	55° C	-
INV MD 4 15.0	ADP MD WDM	50° C	-
INV MD 4 18.5	ADP MD WDM	40° C	-
INV MD 4 22.0	ADP MD WDM	35° C	-

## Température environnante maximale :

Électronique	Adaptateur	Ambiante	Suffixe
INV MC 4 5.5	ADP MC WDM	40° C	S10
INV MC 4 7.5	ADP MC WDM	35° C	S10

## Mentions requises

Boîtier prévu pour une utilisation avec entrées de conduit fileté installées sur le terrain, raccords ou plaques d'obturation approuvées UL conformément à UL514B et certifiées CSA conformément à C22.2 No. 18, étiquetage environnemental de type 1 ou plus.

Le variateur INVEOR INV MC 4 avec le suffixe S10 est exclusivement conçu pour une utilisation en environnement de degré de pollution 2.

La protection interne contre les surcharges se met en marche en l'espace de 60 secondes une fois 150 % du courant nominal du moteur atteints

Convient pour une utilisation sur un circuit capable de livrer pas plus de 5 kA ampères symétriques rms, 230 volts pour INV Mx 2 ou 480 volts pour INV Mx 4 maximum en cas de protection par fusibles.

« Avertissement » – Utiliser des fusibles d'une valeur nominale de 600 V/50 A pour INV MA 2 uniquement.

« Avertissement » – Utiliser des fusibles d'une valeur nominale de 600 V/10 A pour INV MA 4 uniquement.

« Avertissement » – Utiliser des fusibles d'une valeur nominale de 600 V/30 A pour INV MB 4 uniquement.

« Avertissement » – Utiliser des fusibles d'une valeur nominale de 600 V/30 A pour INV MC 4 uniquement.

« Avertissement » – Utiliser des fusibles d'une valeur nominale de 600 V/70 A pour INV MD 4 uniquement.

La protection intégrée contre les courts-circuits à semi-conducteur n'assure pas la protection du circuit de dérivation. Le circuit de dérivation doit être protégé conformément aux instructions du fabricant, au code national d'électricité et à tout autre code local additionnel.

Toutes les bornes de câblage avec repères pour les connexions correctes pour l'alimentation électrique, la charge et les circuits de commande.

Le couple de serrage pour la connexion des bornes du moteur est de 26,55 lb/in (taille A à C) et de 5,31 lb/in pour la connexion CTP (toutes les tailles).

**Pour les instructions destinées à l'opérateur et les instructions de service relatives au montage et à la connexion des produits à l'aide de l'adaptateur de connexion du moteur prévu à cet effet, voir les** Installation du régulateur d'entraînement intégré au moteur **et** Plaques adaptatrices **contenus dans le Manuel d'utilisation.**

Utiliser uniquement des câbles en cuivre 75° C.

Les entraînements ne permettent pas la détection de surtempérature.

Concernant le Mx 4 utilisé au Canada : LA SUPPRESSION DE TENSION TRANSITOIRE DOIT ÊTRE INSTALLÉE CÔTÉ LIGNE DE CET ÉQUIPEMENT ET AVOIR UNE VALEUR NOMINALE DE 277 V (PHASE-TERRE), 480 V (PHASE-PHASE), EN COMPATIBILITÉ AVEC LA CATÉGORIE DE SURTENSION III, ET DOIT OFFRIR UNE PROTECTION CONTRE UN PIC DE TENSION ASSIGNÉE DE TENUE AUX CHOCS DE 2,5 kV

### Température environnante maximale (version sandwich):

Électronique	Dimensions hors tout du dissipateur	Environnante	Suffixe
INV MA 2 0.37	(150x27x210) mm	50° C	Gx3
INV MA 2 0.55	(150x27x210) mm	50° C	Gx3
INV MA 2 0.75	(150x27x210) mm	50° C	Gx3
INV MA 2 1.10	(150x27x210) mm	50° C	Gx3
INV MA 4 0.55	(150x27x210) mm	65° C	Gx3
INV MA 4 0.75	(150x27x210) mm	65° C	Gx3
INV MA 4 1.10	(150x27x210) mm	65° C	Gx3
INV MA 4 1.50	(150x27x210) mm	65° C	Gx3
INV MB 4 2.2	(200x40x250) mm	60° C	Gx3
INV MB 4 3.0	(200x40x250) mm	60° C	Gx3
INV MB 4 4.0	(200x40x250) mm	60° C	Gx3
INV MC 4 5.5	(216x83x300) mm	65° C	Gx3
INV MC 4 7.5	(216x83x300) mm	65° C	Gx3
INV MD 4 11.0	to be defined	to be defined	Gx3
INV MD 4 15.0	to be defined	to be defined	Gx3
INV MD 4 18.5	to be defined	to be defined	Gx3
INV MD 4 22.0	to be defined	to be defined	Gx3

### CONDITIONS D'ACCEPTABILITÉ :

**Utilisation** - Réserve à une utilisation dans un équipement complet pour lequel l'acceptabilité de la combinaison est déterminée par Underwriters Laboratories Inc.

1. Ces entraînements sont incomplets et doivent être raccordés à un dissipateur externe en utilisation finale. Sauf en cas d'utilisation avec dissipateur comme mentionné au point 2 des conditions d'acceptabilité ci-dessous, il est conseillé d'effectuer un test de température en utilisation finale.
2. Le test de température a été effectué avec un entraînement installé sur un dissipateur en aluminium, dimensions hors tout et forme d'ailettes comme indiqué ci-dessous :
3. La possibilité de mise à la terre de la combinaison entraînement et dissipateur doit être vérifiée conformément à la norme d'utilisation finale.
4. Le test de température n'a pas été conduit sur les modèles INV MD 4. Déterminer si la combinaison entraînement - dissipateur est appropriée à l'aide d'un test de température en utilisation finale.

### Mentions requises

La protection interne contre les surcharges se met en marche en l'espace de 60 secondes une fois 150 % du courant nominal du moteur atteints.

Convient pour une utilisation sur un circuit capable de livrer pas plus de 5 kA ampères symétriques rms, 230 volts pour INV Mx 2 ou 480 volts pour INV Mx 4 maximum en cas de protection par fusibles.

« Avertissement » – Utiliser des fusibles d'une valeur nominale de 600 V/50 A pour INV MA 2 uniquement.

« Avertissement » – Utiliser des fusibles d'une valeur nominale de 600 V/10 A pour INV MA 4 uniquement.

« Avertissement » – Utiliser des fusibles d'une valeur nominale de 600 V/30 A pour INV MB 4 uniquement.

« Avertissement » – Utiliser des fusibles d'une valeur nominale de 600 V/30 A pour INV MC 4 uniquement.

« Avertissement » – Utiliser des fusibles d'une valeur nominale de 600 V/70 A pour INV MD 4 uniquement.

La protection intégrée contre les courts-circuits à semi-conducteur n'assure pas la protection du circuit de dérivation. Le circuit de dérivation doit être protégé conformément aux instructions du fabricant, au code national d'électricité et à tout autre code local additionnel.

Toutes les bornes de câblage avec repères pour les connexions correctes pour l'alimentation électrique, la charge et les circuits de commande.

**Pour les instructions destinées à l'opérateur et les instructions de service relatives au montage et à la connexion des produits à l'aide de l'adaptateur de connexion du moteur prévu à cet effet, voir les** Installation du régulateur d'entraînement intégré au moteur **et** Plaques adaptatrices **contenus dans le Manuel d'utilisation.**

Utiliser uniquement des câbles en cuivre 75° C.

Les entraînements ne permettent pas la détection de surtempérature.

Réserve exclusivement à une utilisation en environnement de pollution de degré 2.

Concernant le Mx 4 utilisé au Canada: LA SUPPRESSION DE TENSION TRANSITOIRE DOIT ÊTRE INSTALLÉE CÔTÉ LIGNE DE CET ÉQUIPEMENT ET AVOIR UNE VALEUR NOMINALE DE 277 V (PHASE-TERRE), 480 V (PHASE-PHASE), EN COMPATIBILITÉ AVEC LA CATÉGORIE DE SURTENSION III, ET DOIT OFFRIR UNE PROTECTION CONTRE UN PIC DE TENSION ASSIGNÉE DE TENUE AUX CHOCS DE 2,5 kV







[www.gd-elmorietschle.de](http://www.gd-elmorietschle.de)  
er.de@gardnerdenver.com

**Gardner Denver  
Deutschland GmbH**  
Industriestraße 26  
97616 Bad Neustadt · Deutschland  
Tel. +49 9771 6888-0  
Fax +49 9771 6888-4000

**Gardner Denver  
Schopfheim GmbH**  
Roggenbachstraße 58  
79650 Schopfheim · Deutschland  
Tel. +49 7622 392-0  
Fax +49 7622 392-300

**Gardner**  

---

**Denver**

Elmo Rietschle is a brand of  
Gardner Denver's Industrial Products  
Group and part of Blower Operations.