

# Gardner Denver

OIL-FREE COMPRESSOR

## GD150



The GD150 is a high flow, oil free, radial vane compressor for pressure off-loading of bulk liquids. The most modern materials and manufacturing methods make the GD150 Compressor the most reliable and durable vane compressor available.

- Pressure to 36 psig
- Flow rate to 75 cfm

### Features & Benefits

- 100% oil free air for clean product unloading
- Corrosion resistant, stainless steel rotor will not corrode or de-plate like coated rotors
- Steel shafts for durability and strength
- Viton seals
- High temperature blades
- Lightweight and compact with anodized aluminum body and side plates
- Double ended shaft for clockwise or counter clockwise drive
- Hydraulic drive mounting trucks available for direct coupling of hydraulic motors



## GD150 Performance & Dimensions

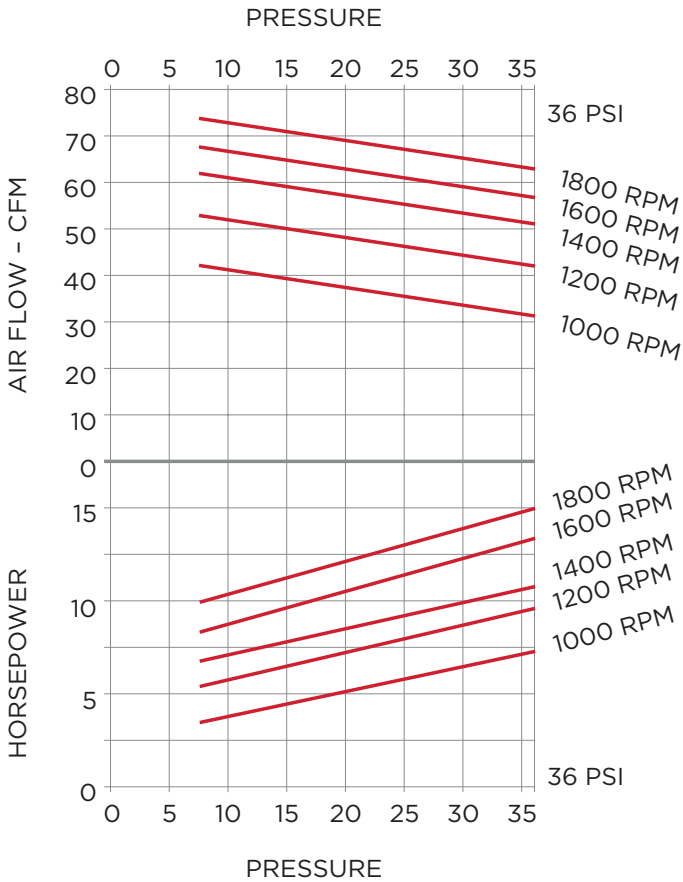

### Accessories

The standard accessories supplied with the GD150 are:

- 1/2" brass check valve
- Pressure relief valve 30 psi
- Detachable mounting feet
- Specially designed aluminum air filter
- 1/2" NPTF port flanges

### Options include:

- 1" stainless steel check valve
- Pressure relief valve 36 psi
- Drive flange
- 3 way ball valve
- Stainless steel mounting brackets

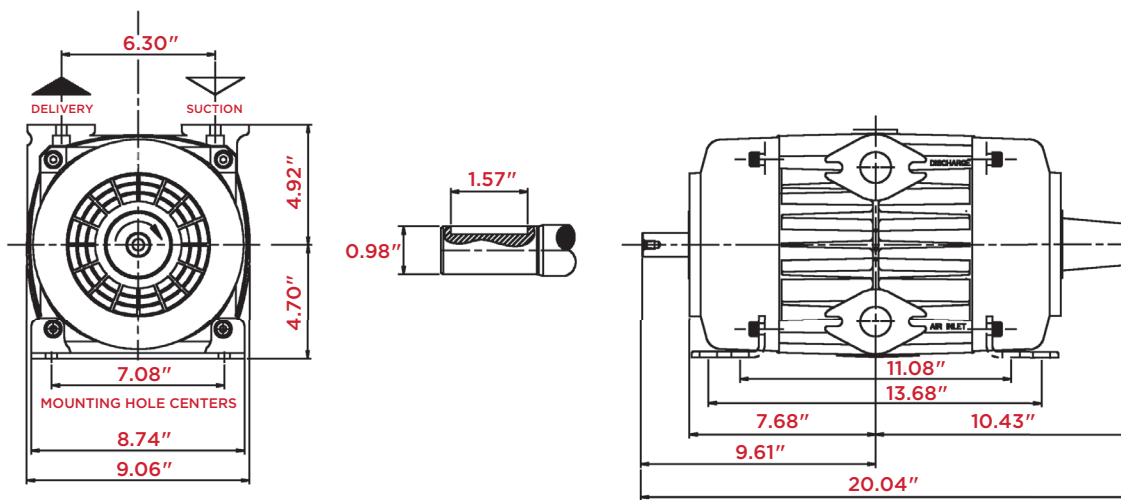

The leader in every market we serve  
by continuously improving all business processes  
with a focus on innovation and velocity

**Gardner  
Denver**<sup>®</sup>

**Gardner Denver, Inc.**

1800 Gardner Expressway  
Quincy, IL 62305  
866-376-8181

[www.gardnerdenver.com/gdproducts](http://www.gardnerdenver.com/gdproducts)



©2020 Gardner Denver, Inc. Printed in U.S.A.  
GDT-GD150 2nd Ed. 2/20

Please recycle after use.