

Gardner Denver

3-10 HP | OIL-LESS | ROTARY SCROLL COMPRESSOR

EnviroAire Series



Legendary Experience

Innovative Design

Gardner Denver has over 150 years of experience in design and manufacturing of the highest quality compressors. The EnviroAire rotary scroll system is the perfect example of our progressive innovation.

Oil-less compressors have become a standard in industries such as medical, lab/research, biotechnology, pharmaceutical, food and beverage, and semi-conductor. Oil contamination is extremely detrimental to these processes. Pure air quality demands are rapidly growing with new regulations and laws regarding oil contamination throughout multiple industries and applications. Gardner Denver has designed the EnviroAire scroll compressor specifically for these applications that require **100% OIL-FREE AIR**, including NFPA & CSA code compliant multiplex systems

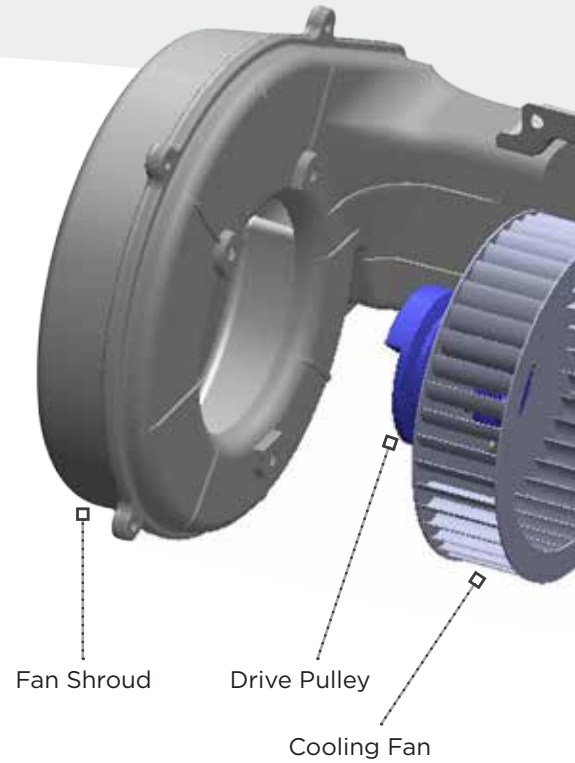

Scroll Compression Explained

- An orbiting (rotating) scroll and fixed scroll housing are mated to create the compression chambers
- The continual movement of the orbiting scroll moves atmospheric air from the intake toward the center, compressing the air into progressively smaller areas
- The compressed air is directed to the center discharge port of the compressor
- Discharge pressure is accomplished during multiple stages of compression, resulting in a continuous intake suction and discharge

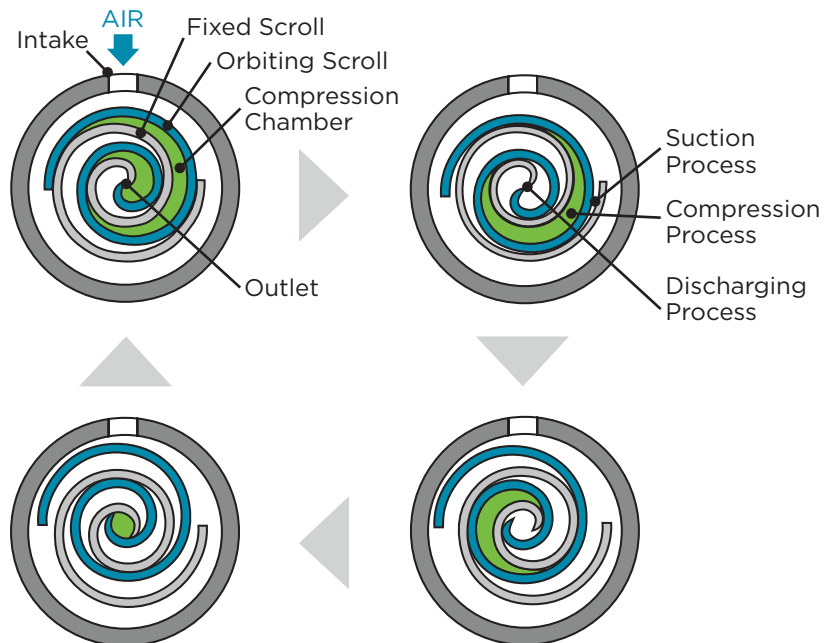

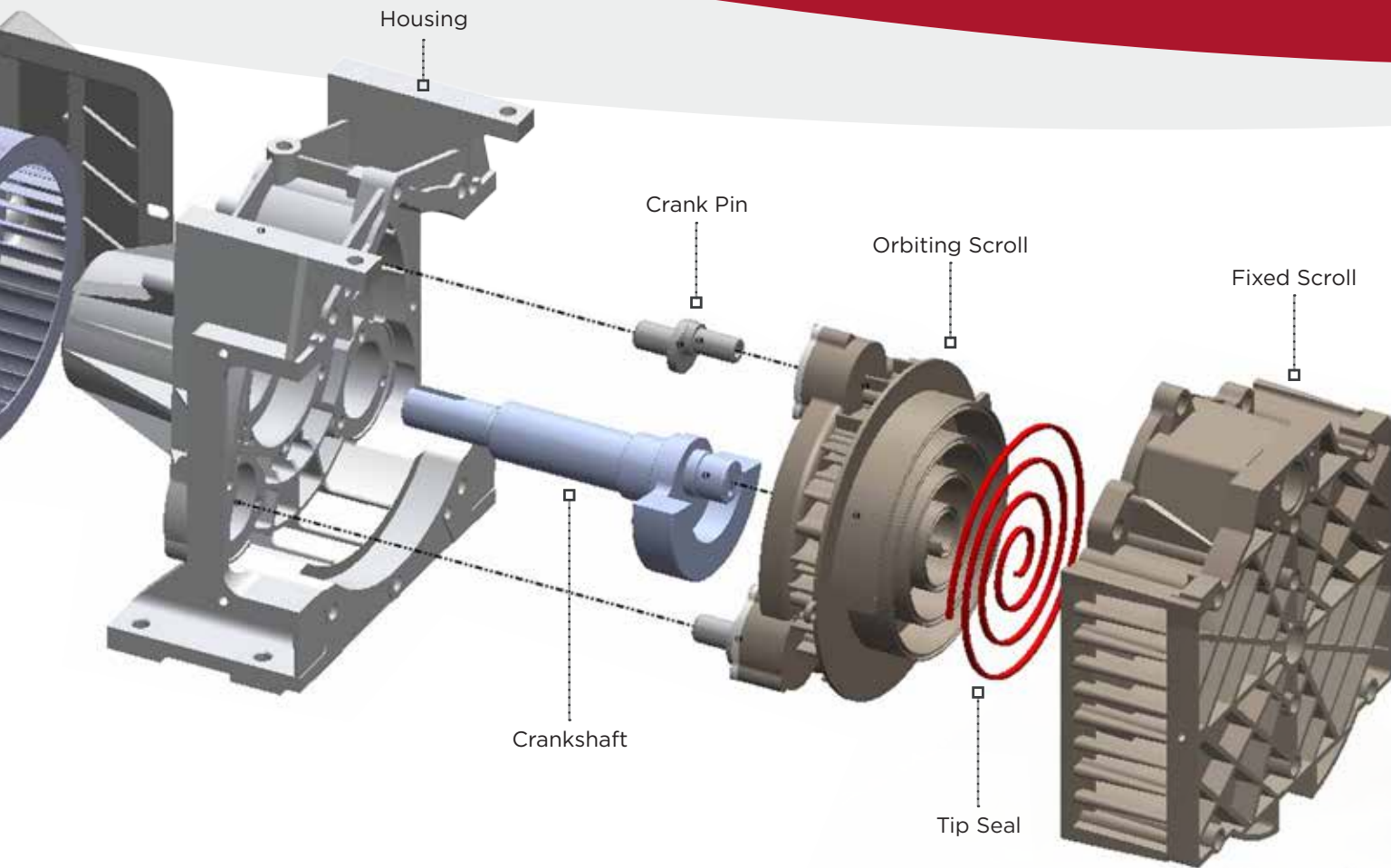

Scroll Compressor Features & Benefits

- 100% Oil-Less Design
- Oil-Free/Contaminant Free Air
- Continuous Operation, 100% Duty Cycle
- Integral Cooling Fan
- Special Tip Seal Design
- 116 or 140 PSI Options
- Low Sound Levels
- Low Vibration
- Compact Footprint
- 3, 5, 7.5 and 10 HP Options
- Flow from 9.2-126.4 CFM @ 116 PSI
- Less Moving Parts, Low Maintenance and High Reliability



Industrial & Laboratory Applications

Gardner Denver designed the EnviroAire Scroll compressor system to meet industrial and laboratory requirements for contaminant free, oil-free, clean air applications. Compressors range from 3-10 HP in simplex through quadraplex designs with optional remote receiver, or available as tank mounted with optional integrated dryer. The EnviroAire modular system creates a clean, simple and serviceable layout, maximizing our ability to meet specific application requirements.

Base Mount
Simplex



Industrial

- Breathing Air (Paint & Cleaning Booths)
- Pharmaceutical
- Food Processing
- Semi-Conductor Industry
- Laser Cutting
- Printing
- Air Bearings
- Instrument Air (Controlled Atmosphere)

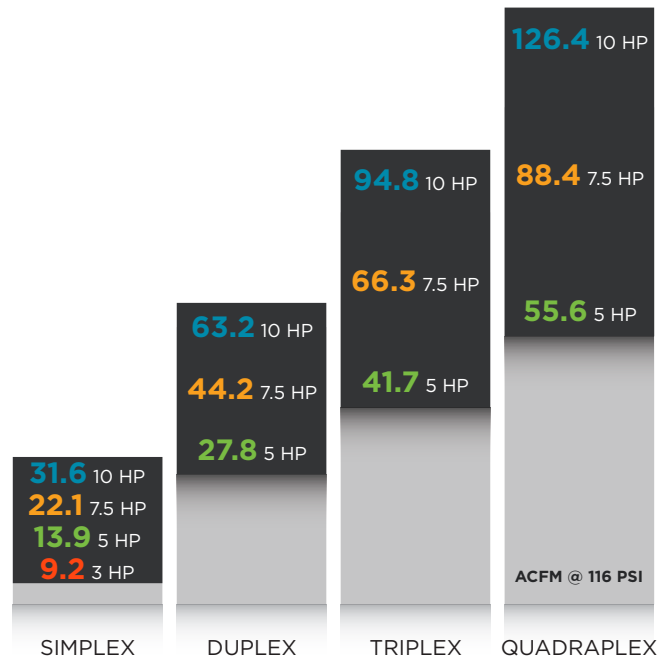

Stacked Multiplex

Duplex



Triplex



Quadruplex



TANK
MOUNTED
SIMPLEX
& DUPLEX
AVAILABLE

Laboratory

- Biotech
- Photo Laboratories
- Lens Grinding
- Dental (Denture Manufacturing)
- Quality Control/Testing





Medical Applications

The EnviroAire medical compressed air systems provide Category 1, NFPA 99 compliant medical breathing air to healthcare facilities and medical institutions. The oil-less scroll design is a proven technology utilized for the most critical of applications. When dependability and longevity are determining factors for your medical application, the EnviroAire scroll system is the perfect choice.

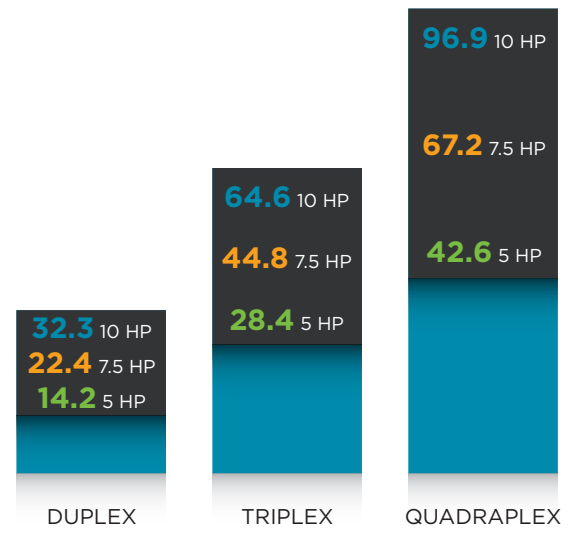
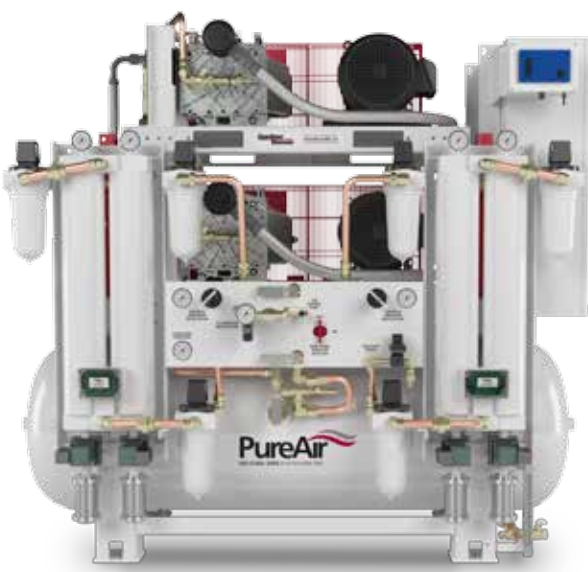

ICFM @ 116 PSI
 Capacities shown are NFPA compliant
 (Reserved Compressor on Standby)

Gardner Denver medical desiccant dryer systems are NFPA 99 and CSA code compliant for medical air applications. The redundant dryer system removes contaminants and moisture delivering dry, clean medical air.

- Duplex Filter and Regulator Bank with By-Pass
- Purge Control with Mufflers
- Tower Gauges
- Pressure Regulators with Gauges
- Isolation Valves
- Differential Gauges on Filters
- Carbon Monoxide and Dew Point Monitoring

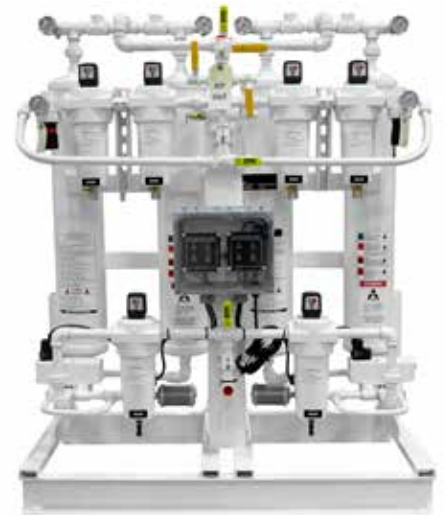

Medical

- Medical Equipment
(Sterilizers, Orbital Arms, Radiation - TomoTherapy)
- Laboratory
(Medical Research, College & High School)
- Medical Air
- Dental Facilities (Procedure)
- HVAC Climate Control
(Healthcare Facilities & College Buildings)



System Controls

The optional Deluxe HMI control and the MediTrol-Plus HMI control from Gardner Denver have easy to use navigation and friendly graphics that deliver interactive and intuitive information at your fingertips. With a built-in integral webserver, BACnet IP protocol via Ethernet connection, these controllers provide visibility to the EnviroAire Scroll compressor system from any computer or mobile device with an internet connection.

Deluxe HMI

- 3.5" Full Color Touch Screen
- PLC Controlled
- Lead/Lag Control with Forced Alternation
- System Capacity and Operation Trending
- 26 Language Options

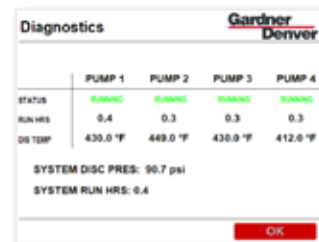

Diagnostics				
	PUMP 1	PUMP 2	PUMP 3	PUMP 4
STATUS	RUNNING	RUNNING	RUNNING	RUNNING
RUN HRS	0.4	0.3	0.3	0.3
DIS TEMP	430.0 °F	449.0 °F	430.0 °F	412.0 °F
SYSTEM DISC PRES: 90.7 psi				
SYSTEM RUN HRS: 0.4				



MediTrol-Plus HMI

- NFPA-99 Category 1 Medical, UL-508a, cULus
- 5.7" Full Color Touch Screen
- PLC Controlled
- Redundant Transformers for Dryer Control
- Analog Inputs for Pressure, RTD's, Dewpoint and Carbon Monoxide
- Lead/Lag Control with Forced Alternation
- System Capacity and Operation Trending
- Maintenance and Service Monitoring

EASY to use Navigation & Friendly Graphics

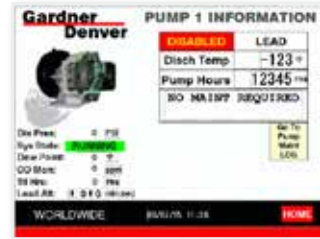

Gardner Denver—the Total Package

Since 1859, Gardner Denver has been selling more than just great products. We've been selling solutions to the compressed air industry through a complete offering of different compressor technologies, air dryers, lubricants, piping, downstream accessories, and genuine Gardner Denver parts. Our focus on providing total system solutions ensures your focus remains on running your business.

Refrigerated Air Dryers, Desiccant Air Dryers, and Medical Desiccant Air Dryer Systems

Compressed air systems require clean dry air with environmentally sound disposal of by-products. That is why Gardner Denver support does not stop at the compressor. Proper removal of contaminants is essential in preventing costly damage to equipment. Gardner Denver provides a broad range of dryers, filters, separators, drains, and other downstream products to ensure total system reliability.

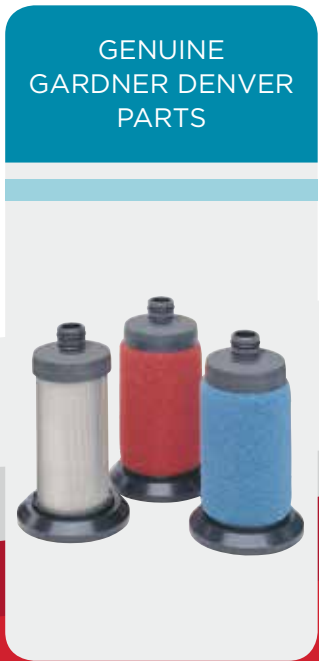

Sales & Service **Distributors** Across America

An Extensive Network

By leveraging the extensive network of Gardner Denver factory-trained authorized local distributors—your sales, service, and technical support needs can be handled quickly and easily.

To find a distributor visit:

<http://gardnerdenverproducts.com>



The leader in every market we serve
by continuously improving all business processes
with a focus on innovation and velocity

**Gardner
Denver**[®]

Gardner Denver, Inc.

1800 Gardner Expressway
Quincy, IL 62305
866-440-6241

www.gardnerdenver.com/gdproducts



©2017 Gardner Denver, Inc. Printed in U.S.A.
GL-ENVIROAIRE 1st Ed. 2/17

 Please recycle after use.