

260Z Series

THOMAS
by Gardner Denver

FEATURES

- > Unique head/cylinder design
- > Oil-less operation
- > Permanently lubricated bearings
- > Stainless steel valves
- > Pressure or Vacuum Capability
- > High performance piston seal
- > Die-cast aluminum components
- > Thin wall, hard coated aluminum cylinder
- > Wetted parts treated for corrosion resistance
- > Dynamically balanced
- > Designed and tested per Agency standards
- > Brushless DC motor
- > RoHS compliant

TYPICAL APPLICATIONS

- > Portable Oxygen Concentrator
- > Small Analytical Equipment
- > Instrumentation
- > Ambient Scenting
- > Lab Automation

CUSTOMER REQUIREMENTS

- > Supplemental cooling air flow to compressor to be integrated into thermal management system to ensure that proper installation and operating environment is maintained in keeping with the product specifications
- > BLDC motor requires motor controller - SKCNTLR optional Thomas controller available in sample quantities

BASE MODEL

260ZC35/24



WOB-L

260Z Series

Flow	1.77 cfm (50.1 l/min)
Max. pressure	30 psi (2.1 bar)
Max. vacuum	87% local barometer

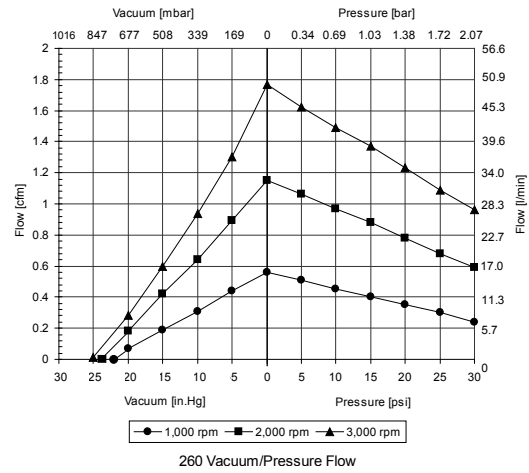
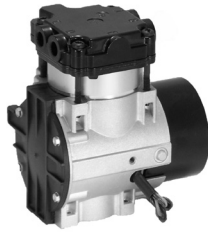

PERFORMANCE DATA

Model Number	260ZC35/24		
Head Configuration	Pressure/Vacuum		
Stroke	0.35 in. (8.9 mm)		
Nominal voltage input	24V DC	24V DC	24V DC
Variable output speed	1,000 rpm	2,000 rpm	3,000 rpm
Max. open air flow	0.56 cfm (15.9 l/min)	1.15 cfm (32.6 l/min)	1.77 cfm (50.1 l/min)
Max. rated pressure	30 psi (2.1 bar)	30 psi (2.1 bar)	30 psi (2.1 bar)
Current at rated pressure	3.3A	4.8A	6.0A
Power at rated pressure	79W	115W	143W
Max. pressure restart	30 psi (2.1 bar)	30 psi (2.1 bar)	30 psi (2.1 bar)
Max. vacuum	23.8 in Hg (806 mbar)	24.7 in Hg (836 mbar)	25.5 in Hg (864 mbar)
Max. vacuum restart	23.8 in Hg (806 mbar)	24.7 in Hg (836 mbar)	25.5 in Hg (864 mbar)

ELECTRICAL DATA

Motor Type	10 Pole BLDC
Motor Insulation class	F
Motor protection	Thermally protected
	Optional SKCNTLR Thomas controller disables motor for stall, amps
Power lead wire color, gauge	Green (phase A), black(phase B), red (phase C), 18 AWG
Hall sensor wire color, gauge	Yellow (Hall+), brown (HS1), orange (HS2), blue (HS3), gray (Hall -), 22 AWG
Thermistor wire color, gauge	Violet (Thermistor), 22 AWG

GENERAL DATA

Operating ambient temperature	50° TO 104° F (10° to 40°C)*
Safety Certification	Consult factory
Net weight	2.78 lbs (1.26 kg)

*Broader ambient operating ranges may be possible depending on your specific application. Please consult factory regarding your particular system needs.

PRODUCT DIMENSIONS

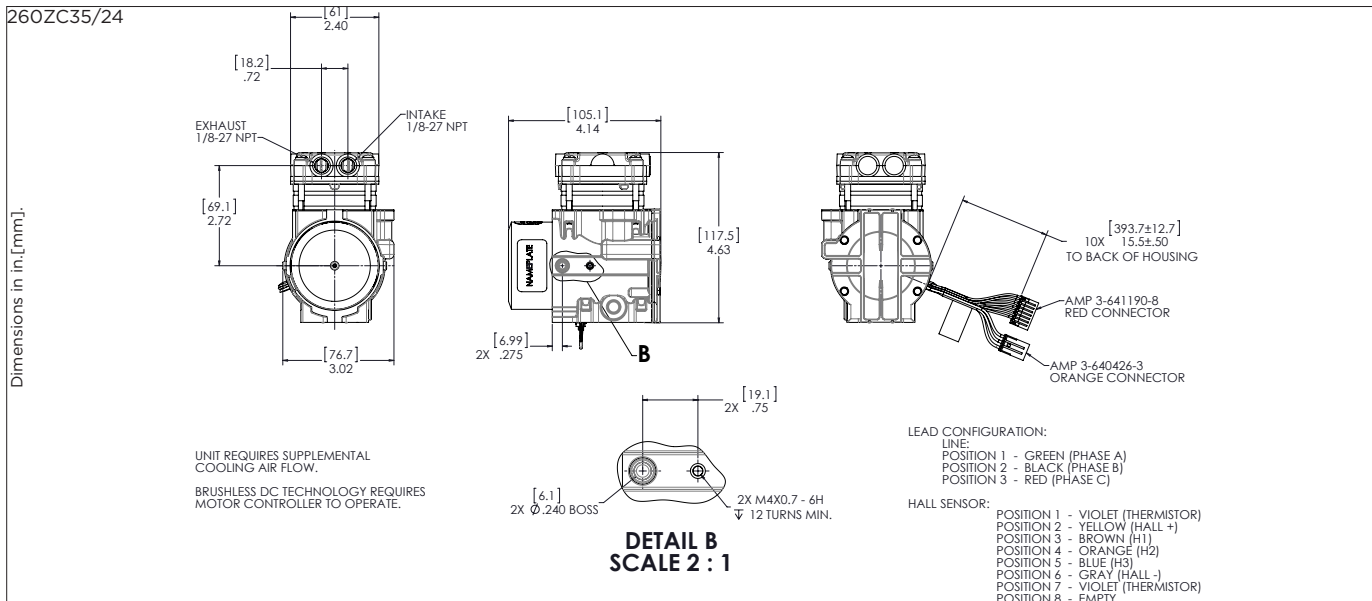

PUMP AND COMPRESSOR SOLUTIONS FOR OEMS WORLDWIDE

gd-thomas.com



Gardner Denver Thomas GmbH

Livry-Gargan-Str. 10
82256 Fürstentfeldbruck
Germany
T +49 8141 2280 0
F +49 8141 8892136

thomas.de@gardnerdenver.com

Gardner Denver Thomas Pneumatic Systems (Wuxi) Co. Ltd.

1 New Dong'an Road, Suofang Town
Xinwu District, Wuxi
Jiangsu, 214142 P.R. China
T +86 510 6878 2217
F +86 510 6878 2200

thomas.cn@gardnerdenver.com

THOMAS

by Gardner Denver

Gardner Denver Thomas, Inc.

1419 Illinois Avenue
Sheboygan, WI 53081
USA
T +1 920 4574891
F +1 920 4514276

td.usa@gardnerdenver.com

The information presented in this material is based on technical data and test results of nominal units. It is believed to be accurate and reliable and is offered as an aid to help in the selection of Thomas products. It is the responsibility of the user to determine the suitability of the product for the intended use and the user assumes all risk and liability in connection there with. Thomas does not warrant, guarantee or assume any obligation or liability in connection with this information.

Models presented in this catalog are representative of the product family. Photos of products pictured in this catalog do not necessarily represent a specific model number. To obtain further information for custom options, contact your local Thomas office.

Printed in U.S.A Form No. 850-4012 10/2018 © Gardner Denver Thomas, Inc. All rights reserved.